

Trench Etched Resonant Pressure Sensor: *TERPS*

Russell Craddock & Peter Kinnell
GE Sensing,
Fir Tree lane,
Groby, UK LE6 0FH

INTRODUCTION

High precision pressure sensors based on resonating techniques have been manufactured for many years but use large transducer components and often have unwieldy media isolation techniques. This paper presents a MEMS Resonant Pressure Transducer (RPT) that is produced using a flexible fabrication route to allow pressure ranges from 1bar to 700bar in fully oil isolated hermetic packages without compromising sensor performance. The key aspects of the fabrication process and sensor design that make this possible are presented. Data showing long-term stability of better than 100ppm drift per year are presented. This paper discusses a new silicon based transducer design that can be packaged for use in a harsh environment in a small form factor.

Existing Pressure sensor technologies

Metal devices

Strain Gauges

Invented in 1938 traditional strain gauge sensors employ the change in resistance of a metal foil or wire as its shape is deformed. In simple terms this is the increase in length of the wire and the corresponding decrease in cross sectional area due to Poissons's ratio. This shape change increases the resistance as electrons are forced to flow further, and are "crowded" by the decreased cross sectional area. (The opposite is also true- the wire can be compressed creating a decreasing resistance). The change in resistance caused by strain- or Gauge factor is typically around 2.

These strain gauges are often bonded onto diaphragms in a Wheatstone bridge arrangement to create pressure sensors.

A major disadvantage in these sensors is the limitation in signal due to the material properties of the foil or wire. The material can only be strained until it's elastic limit beyond which a permanent deflection and hence resistance is created. Typically a limit of 3mV per volt of excitation is employed to maintain an acceptable industrial pressure hysteresis of <0.1% full-scale output. Thermal hysteresis is also created by the thermal expansion mismatch between the strain gauge material and the diaphragm material.

Brittle and crystal materials

Moving away from metal strain gauges to brittle materials avoids the pitfalls of material yield and plastic creep. The materials of choice are typically quartz or silicon with the latter having the advantage of the quality and availability driven by the semiconductor industry.

Silicon Piezoresistive Pressure sensors

Silicon Piezoresistive sensors derive from Smith's (1) discovery of the piezoresistive effect in discrete silicon resistors (Piezoresistance itself was discovered by Lord Kelvin in 1856). Commercial silicon pressure sensors became available in the early 70's with the GE legacy brand Druck starting production in 1972.

Unlike strain gauges piezoresistive gauges do not change their resistance due to the change of shape of the resistors but instead due to the separation of the, normally equal, energy band in the semiconductor, due to the stress created by applied forces. This causes increase in the ratio of high mobility carriers with respect to the low mobility carriers in one axis and consequent decrease in resistivity. A Gauge factor of ~200 is possible ~100x that of simple strain gauges.

The advantages of silicon piezoresistive pressure sensors are the high output levels, 20mV/V is typical and the virtual non-existence of pressure hysteresis due to the brittle nature of the silicon crystal. The disadvantages are the requirement to correct the temperature coefficient of the piezoresistive coefficients (~2000ppm/°C), and the long term drift in the resistors due to, for instance, surface charge effects These drifts create a 0.1%/year drift in a typical commercial sensor although well designed sensors such as GE Druck's Harsh Environment products can have significantly better performance.

Silicon Capacitive Pressure Sensors

Silicon capacitive pressure sensors rely on measuring the change in deflection of a diaphragm. They have the same advantages of the brittle silicon crystal that piezoresistive sensors have and avoid the issues of resistor stability. Often they are used in absolute devices where the capacitive plates can be maintained in a vacuum. This helps avoid one of the causes of error: change in the dielectric between the capacitor plates. The other difficulty in the technique is the difficulty in measuring the small capacitance changes that are created. These changes can be swamped by the wire-bond interconnects in the assembly and by changes in the detection circuit itself. Despite the difficulties relatively low accuracy silicon capacitive products exist in particular accelerometer devices where deflection can be created with low stresses –giving high over-range levels. Higher accuracy products can be created in limited applications for instance benign environment, capacitive absolute barometric sensors exist with stabilities of 0.01%/yr

Quartz pressure sensors

Quartz "Mechanical" sensors

By relying on the brittle nature of fused quartz a number of interesting mechanical structures can be created. These can be capacitive- similar to silicon devices or more interestingly based on the Bourdon tube principle such as a mechanical pressure gauge. In this latter device a coiled tube of fused quartz is pressurized creating a rotational force as the tube tries to "un-roll". This deflection can be measured using capacitive or inductive techniques or as the GE legacy brand Ruska the force required to prevent the un-rolling measured. This latter, force feed back technique, gives the Ruska 7250 instrument a precision of 50ppm of reading. The disadvantage of this technique is the size and fragility of the sensor rendering it useful only in precision instruments.

Quartz Resonant Sensors

A number of manufacturers produce transducers relying on the piezoelectric effect to drive the quartz sensor into resonance much like a quartz crystal oscillator. Stretching or compressing the resonating structure changes the resonance of the crystal. Either mechanical linkages or quartz diaphragm structures are used to create this force. These true crystal quartz devices can be manufactured to be highly accurate sensors but tend to be bulky devices often requiring significant transducer packaging to contain the mechanical linkages. As with the quartz Bourdon tube they often fragile and used as laboratory instruments although transducers are also marketed. Typically the transducers require significant packing to create a product capable of use in harsh environments. The quartz sensor element is generally large compared with a silicon-based element that has the advantages of batch manufacture and precise microelectronics processing.

Silicon Resonant Sensors

Similar to crystalline quartz resonating transducers silicon resonant sensors rely on the stretching of a structure to change the frequency of the transducer.

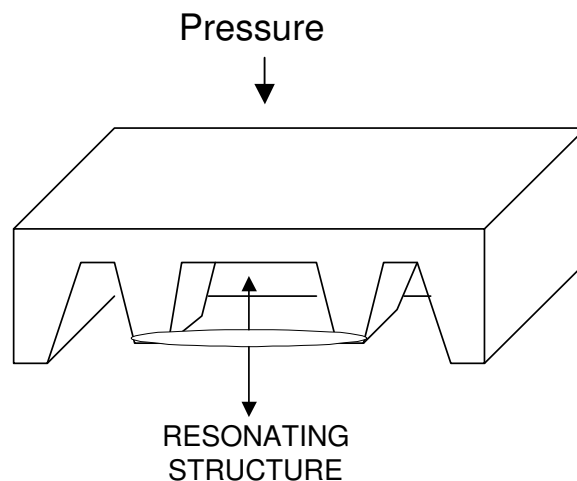

Fig 1 Resonant pressure sensor operation

Unlike many of the quartz sensors, silicon resonating pressure sensors employ a crystalline diaphragm structure “on-chip”. These allow a small silicon device without the need of the complex mechanical linkages used to strain the elements in some quartz devices. Some examples of mature products are those based Yokagawa’s “Dharp” and GE Sensing’s “RPT” MEMs pressure elements. These devices differ on both construction and drive/sensing configuration. The Dharp is manufactured using surface micromachining on a silicon diaphragm creating a double-ended tuning fork configuration inside a vacuum-sealed poly-silicon “tunnel”. The device is operated as a differential pressure sensor in number of process transmitter products with a quoted stability figure of 0.1%/10 yrs. It is driven to resonance using an external magnetic field and is limited by extremes of temperature and compact packaging- but is well suited for it’s application in bulky high line differential pressure process transmitters. GE Druck’s RPT has been manufactured for 18years with a stability of 0.01%/year and accuracy of

<0.01% Full Scale including temperature effects. Unlike the Yokogawa, device that relies on poly-silicon to create the resonator, the GE Druck RPT is a resonator and diaphragm manufactured with entirely single crystal silicon. The device is driven into oscillation electro-statically and sensing by charge output creating a compact structure that can be packaged in an internal diameter <7.5mm.

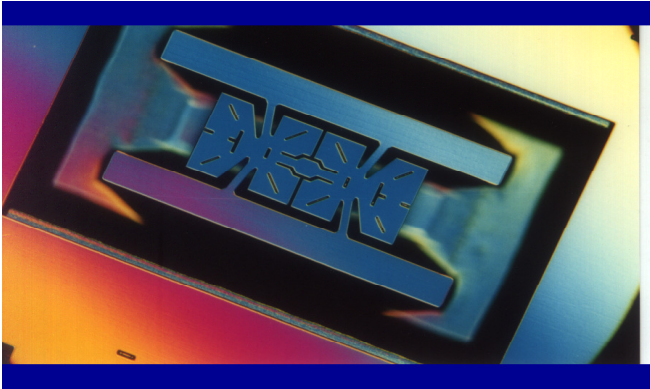

Fig 2 GE Druck RPT single crystal silicon element.

The TERPS Device

The RPT has been a very successful product but has a maximum pressure range of 3.5Bar and limited media compatibility. We have been perfecting its replacement for some years concentrating on flexible manufacture of a MEMS resonating pressure sensor capable of pressure ranges beyond 700Bar with media compatibility as a key consideration.

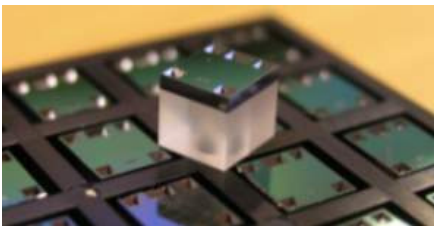

Fig. 3. Photograph of a TERPS die.

The resonator has been specifically optimised such that it may be operated in media isolated harsh environment packages. There are two key aspects of the resonator design that allow this. The first is the use of a patented low impedance piezoresistive outputs so the resonator can be operated in a closed loop with reduced influence from parasitic capacitances. The second is the optimised resonator geometry that creates a lateral resonator mode. This mode is designed to be a fully mechanically balanced, which allows high resonator quality factors independent of the pressure media or isolation fluid.

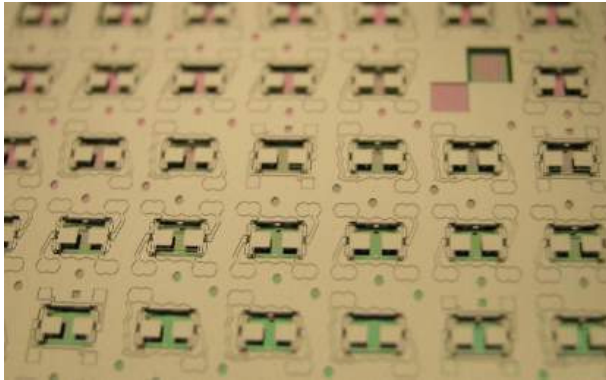

Fig 4 Picture of the TERPS structure

The sensor die is hermetically isolated from the pressure media by a metallic isolation diaphragm within a vacuum oil filled chip cavity. The diaphragm structure has been optimized to prevent the thermal expansion of the oil creating thermal hysteresis. The die uses three technologies: silicon-on-insulator (SOI) wafers; direct silicon fusion bonding (SFB); and deep reactive ion etching (DRIE) to produce die as shown in Fig 4. These technologies are now commonplace in MEMS facilities and offer well-defined and controlled processes.

The key advantages of these techniques are:

Well defined resonant: frequency by using SOI to control thickness and mass of resonating structure.

Insensitive of media viscosity: by using DRIE to create well defined patent structures for dynamic mass and force balance.

Harsh media Isolation: by using DRIE to manufacture complex low impedance sensing technique.

Low thermal and pressure hysteresis: by using SFB to assembly single crystal silicon wafers without the use of adhesives, solders or glass frits.

Performance

The consideration of packaging at the die design stage has allowed the new die to be packaged in isolated hermetic packages with no significant impact on resonator operation and long-term stability. Figs 5 and 6 show curves plotting sensor offset and full scale for a range of die from fully isolated to fully unconstrained. It can be seen that over an 18-month the offset and full scale output shifted by less than 0.01% of full scale.

18 months UKAS lab stability data - Full scale

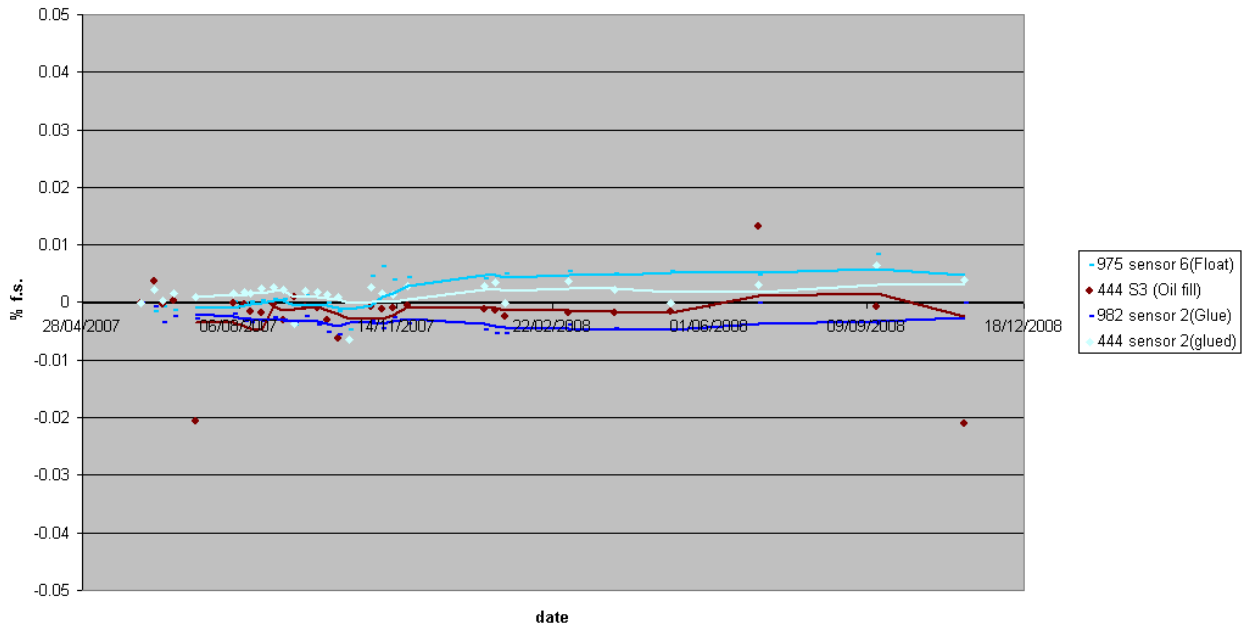

Fig 5 Full scale output stability

18 months UKAS lab stability data - Offset

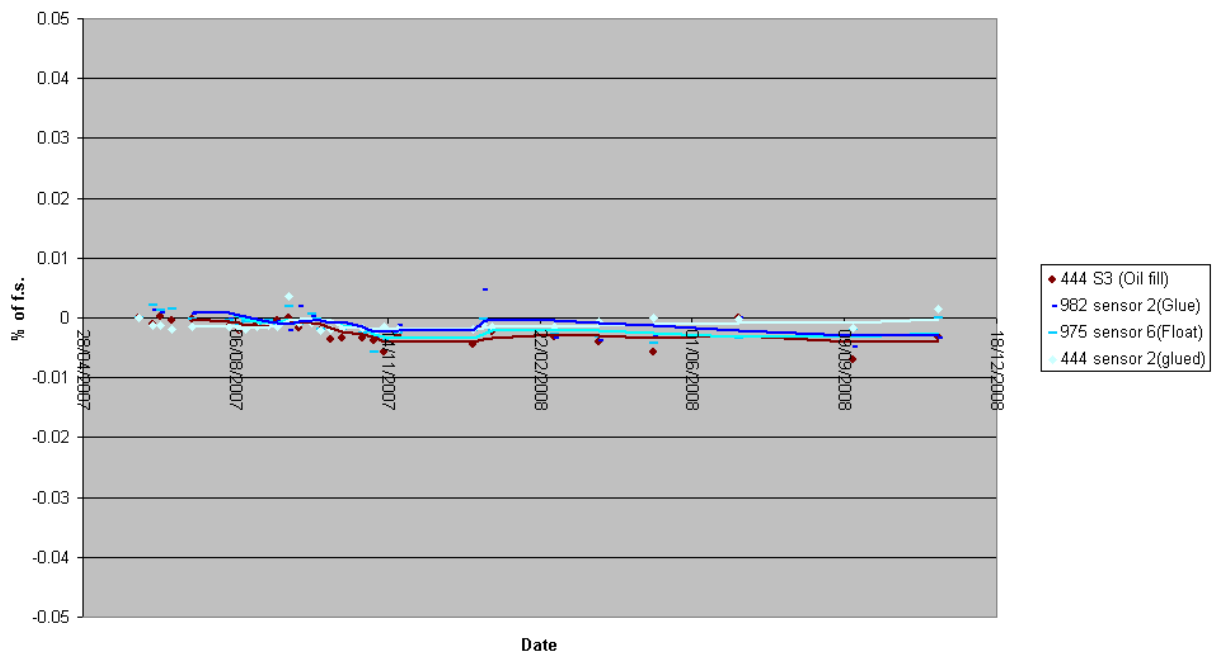

Fig 6 Offset stability

Equal important to stability is the accuracy of the device. The TERPS device is presently packaged for operation from -54°C to 125°C and over this temperature range the

frequency output of the resonator and temperature signal are combined by polynomial curve-fitting to create a performance of better than $<0.01\%$ of Full Scale pressure.

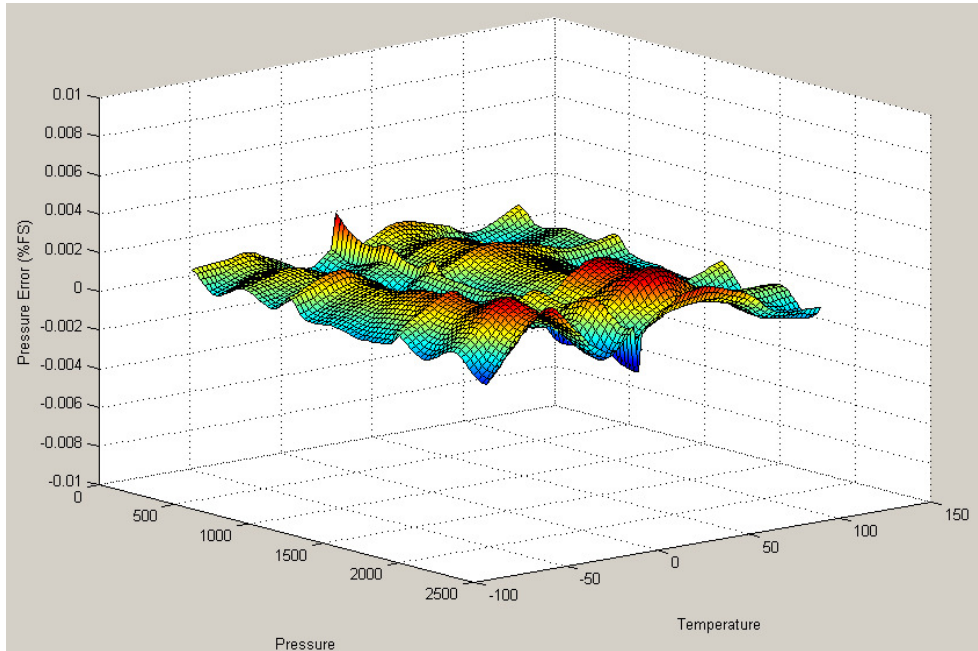

Fig 6 Curve-fit accuracy

Conclusion

GE Sensing of created a new range of media isolated pressure sensors capable of achieving 0.01% Full-scale accuracy and $0.01\%/year$ stability.