

# LAND



# SOLO<sub>net</sub>

A new generation of intelligent compact digital infrared thermometers



# LAND

Land Instruments International Ltd • Dronfield S18 1DJ • England  
Email: [land.infrared@ametek.co.uk](mailto:land.infrared@ametek.co.uk) • [www.landinst.com](http://www.landinst.com) • Tel: +44 (0) 1246 417691 • Fax: +44 (0) 1246 410585

AMETEK Land, Inc. • 150 Freeport Rd • Pittsburgh, PA 15238 • U.S.A.  
Email: [irsales@ametek.com](mailto:irsales@ametek.com) • [www.ametek-land.com](http://www.ametek-land.com) • Tel: +1 (412) 826 4444 • Fax: +1 (412) 826 4460

Non-Contact Temperature  
Measurement Solutions

For a full list of international offices, please visit our website.



An **AMETEK** Company

Applies in the UK

Applies in the USA

An **AMETEK** Company

# SOLOnet



## The new generation of intelligent, high precision digital infrared thermometers

SOLOnet is the world's first compact web browser enabled infrared thermometer system offering the user maximum flexibility and connectivity. With SOLOnet the user can configure the thermometer system to suit his individual measurement and control requirements.

Live temperature data is displayed on a PC or computer system via the web browser, together with related measurement parameters for ease of configuration. The parameters are easily adjusted and saved using drop-down menus or text windows.

Typically, end users will appreciate the convenience of configuring the thermometer via a standard web browser, such as Internet Explorer or Netscape Navigator. Advanced users and OEMs will benefit from a lower-level interface with direct messaging via Ethernet or addressable RS485.

There are four different thermometer types with choice of operating wavelength, optical variants, laser alignment and measurement ranges to suit the chosen application within the operating range 200 to 1750°C/392 to 3182°F. The measurement span can be selected within the thermometer range, with the minimum measurement span being 50°C/90°F.

## Features

- Intelligent, digital infrared thermometers with flexible methods of configuration
- RS485, Web browser or Ethernet interface
- High precision inputs/outputs, both digital and analog formats
- Simple and easy to configure to user requirements
- Field changeable optics without need to recalibrate or any additional parts
- Sapphire window is standard on all models - robust, low maintenance
- Laser alignment option
- Built-in peak picker, track & hold and averager time functions
- Choice of alarm outputs, including 'insufficient signal' alarm for ratio thermometers
- Rugged, sealed aluminium housing
- Optional water cooled and air purged mountings and accessories
- Two year warranty

## Benefits

- Improve product quality
- Maximize production and throughput
- Improve efficiency
- Reduce energy costs

User configurable between four focus distances with robust sapphire protection window as standard.

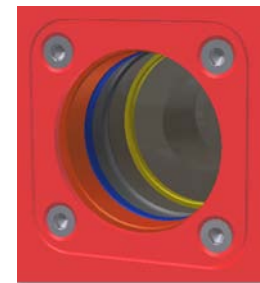

A wide choice of thermometer protection, cooling and mounting options.



Optional laser targeting system, activated remotely or from the thermometer.



## Advantages of SOLOnet digital thermometers

**SOLOnet offers OEMs, system builders and end users virtually limitless flexibility of choice making system integration simpler and easier than before.**

- Completely user configurable remotely via web browser, Ethernet or RS485
- Flexibility of choice of inputs/outputs and alarm types
- Flexibility of choice of interface
- Simple, compact installation
- Accurate, repeatable, fast response measurements
- Highly interchangeable
- Traceability of calibration to National Standards

## Multi point system for process control - permanent monitoring by PC

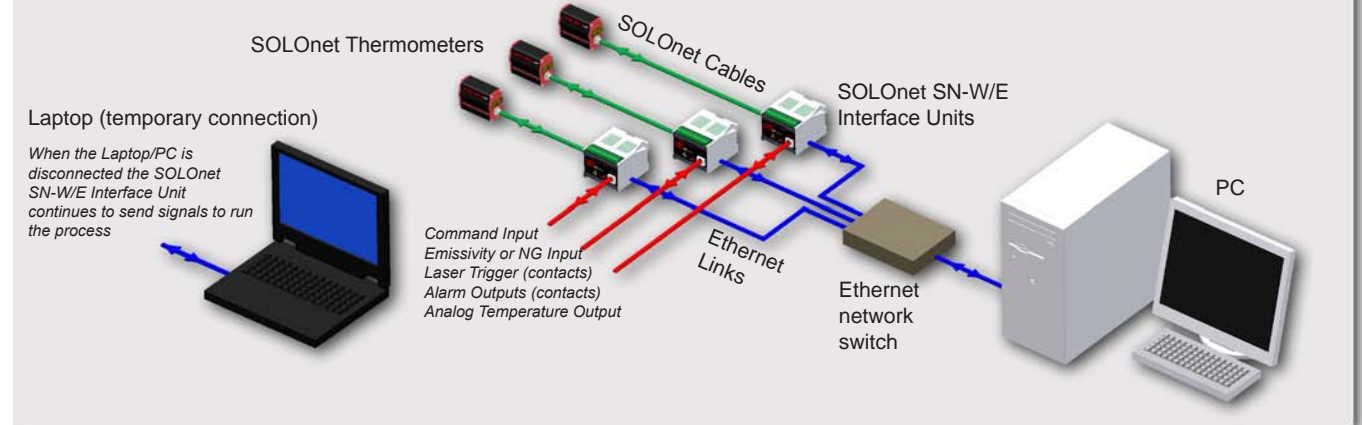

## Multi point system using digital PLC or data acquisition system

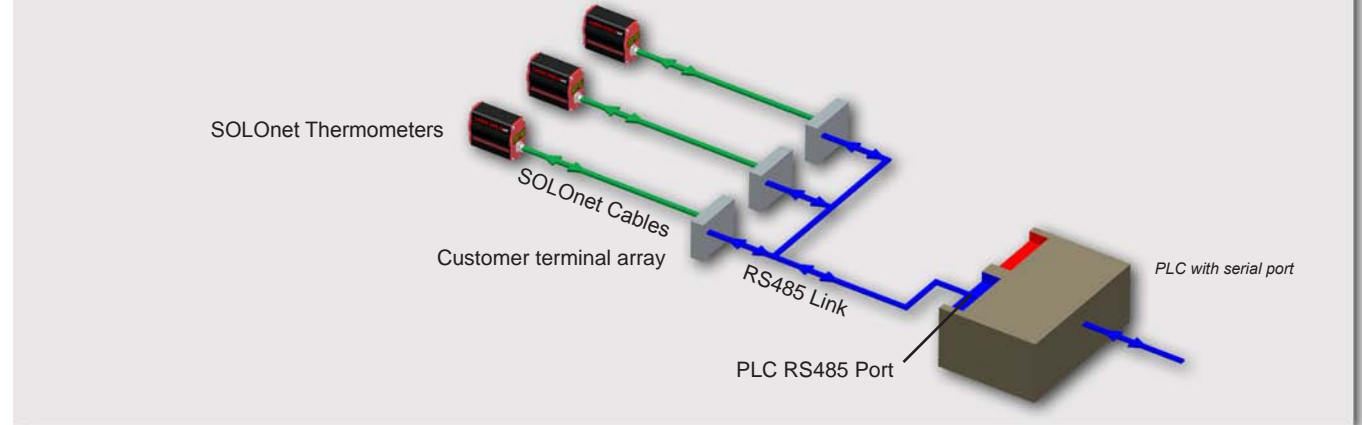

## Multi point system using digital and analog PLC

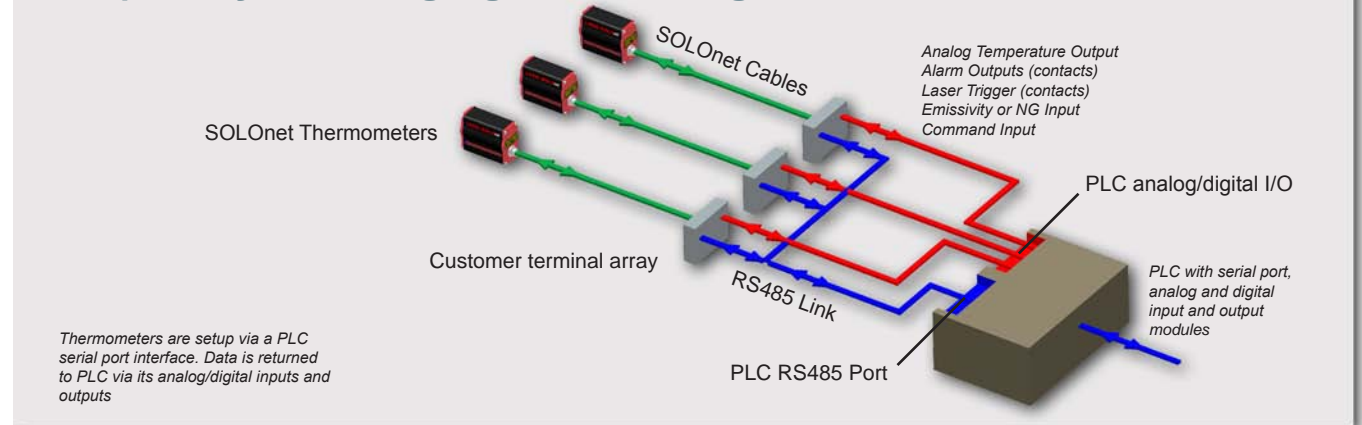

## Thermometer mountings and accessories



Air cooled protection jacket with air purge.

For use in ambient temperatures exceeding 60°C/140°F or where radiant heat levels are high.



Water cooled protection jacket with air purge.



Mounting plate with air purge for use in ambient temperatures up to 60°C/140°F.



Dual and single axis mounting brackets for adjustable sighting.

## Connectivity

The following diagrams are only intended to give a range of examples illustrating the flexibility of SOLOnet connectivity. If your application differs from those illustrated please contact us for information on how SOLOnet can be configured to suit your specific requirements.

### Simple stand alone system

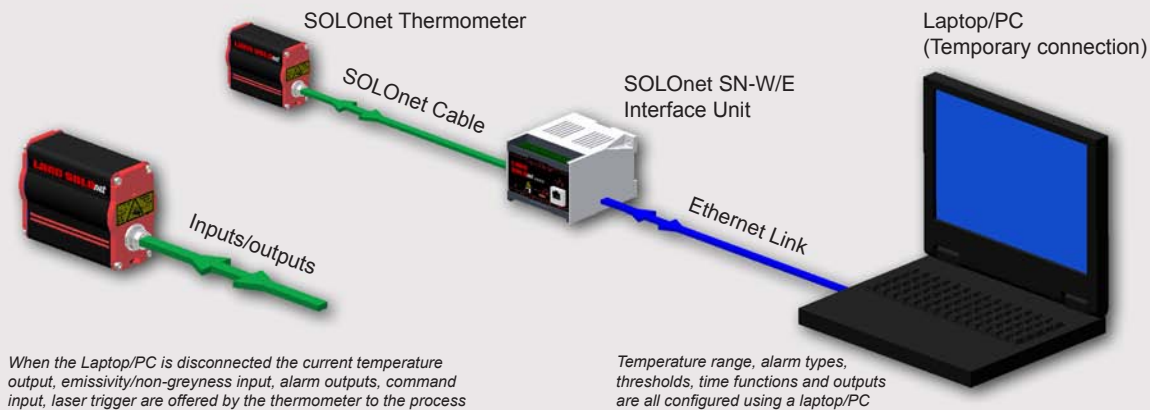

### Single thermometer system for process monitoring

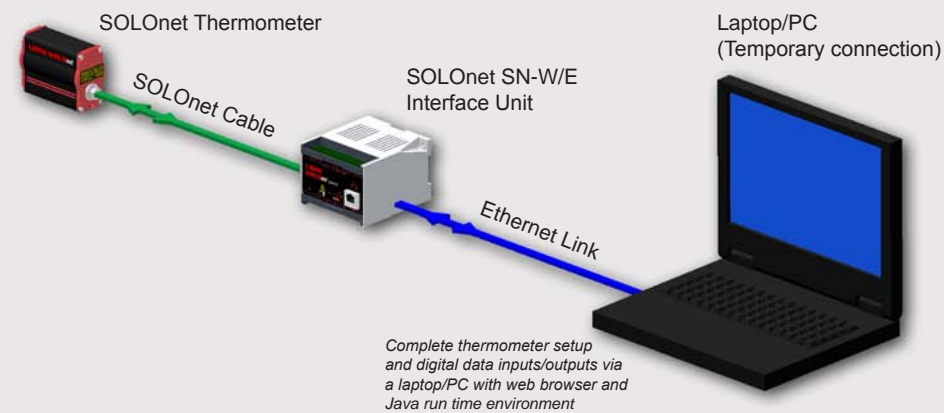

### Multi point system for process monitoring

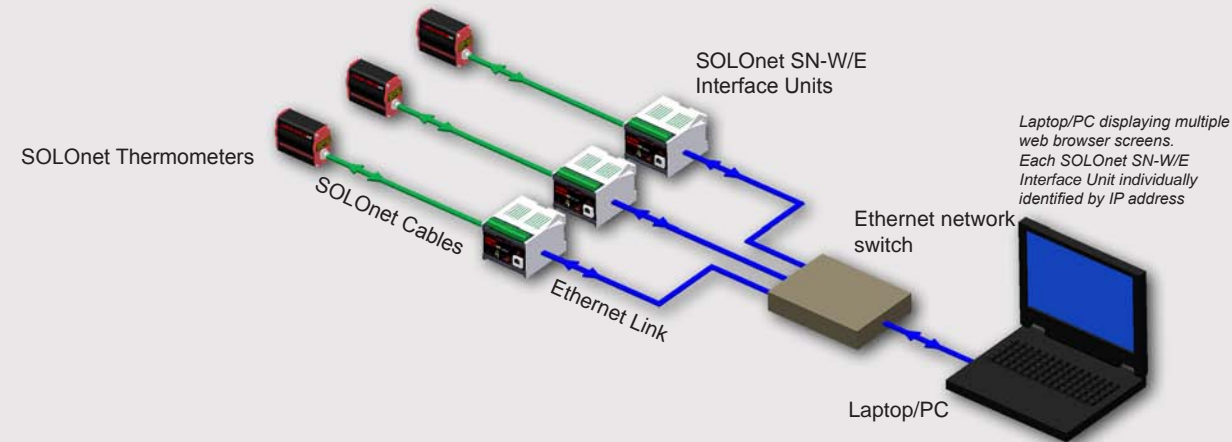

## Great value, versatile signal processing

The SOLOnet series of infrared thermometers provides cost effective, reliable measurement in a wide variety of process control applications.

SOLOnet can be used in stand-alone, single point or multipoint installations with individually, remotely adjustable sub-temperature ranges, current output, emissivity or non-greyness compensation and end user defined alarms settings.

Choice of built-in peak picker, track and hold or averager signal processing functions ensures accurate measurement of difficult or complex processes.

The optional DIN-rail mounted SOLOnet Webserver/Ethernet Interface Unit provides the user with a wide choice of configuration, interconnection, system monitoring and maintenance options.

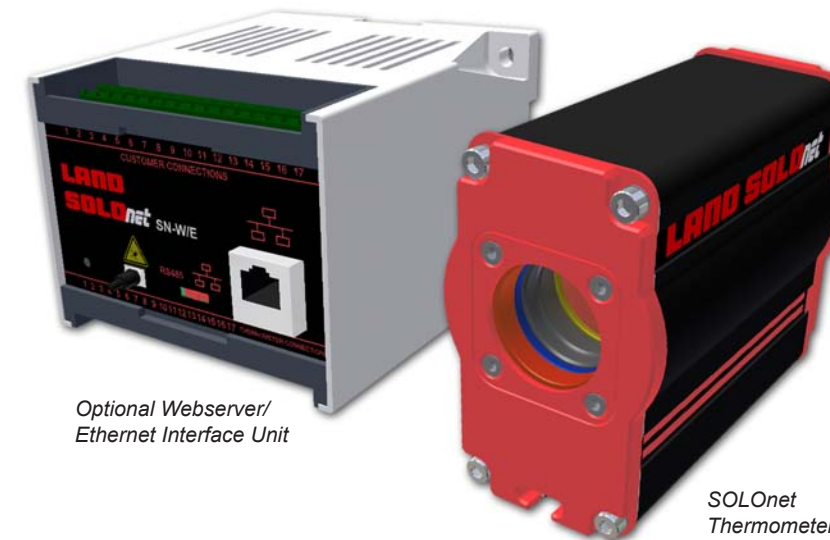

## Easy user configuration

- Configured from a laptop, PC, PLC or computer system with either temporary or permanent connection
- Stand-alone, single or multipoint systems individually addressable and configurable with independent operation
- SOLOnet Web/Ethernet Interface Unit provides simple system interconnections
- Familiar Windows operating environment
- Set up via standard web browser - no proprietary software required - or from customer/OEM process computer
- Choice of prewired cable assembly lengths for ease of installation



## Applications

The SOLOnet series of thermometers are suitable for a wide range of manufacturing and processing industries such as: ferrous and non-ferrous metals, glass, minerals, ceramics, chemicals, electronics and research and development.

Model	Temperature	Typical applications
SN11	550 to 1750°C/ 1022 to 3182°F	Heat treatment, forging, welding, induction heating, soldering, hardening, chain annealing, ceramics, glass gobs, sub surface glass
SN21	250 to 1300°C/ 482 to 2372°F	Heat treatment, preheating, induction heating, welding, hardening, annealing, non ferrous metals moulding, aluminium welding, glass moulds
SN51	200 to 1100°C/ 392 to 2012°F	Toughening/tempering, annealing, automotive glass, architectural/decorative glass, glass containers, forming, stem/base seal, pinch seal, Sealex machine, phosphor coating, curing exit
SNR1	700 to 1750°C/ 1292 to 3182°F	Forging, welding, induction heating, soldering, hardening, chain annealing, heat treating, pipe bending, precious metals melting, automotive components, lamp wire draw and anneal, lamp black glass drop

## Sighting and Dimensional Diagrams

SOLOnet offers a choice of 4 field changeable, fixed-focus optical configurations focused at 250, 500, 1000mm or infinity. The optics are simple to change using a colour coded spacer system for ease of identification - no need for recalibration - no additional parts required.

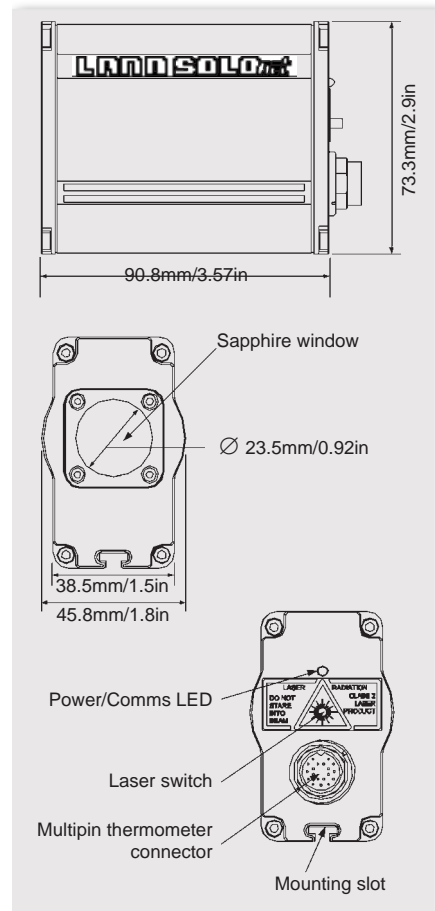
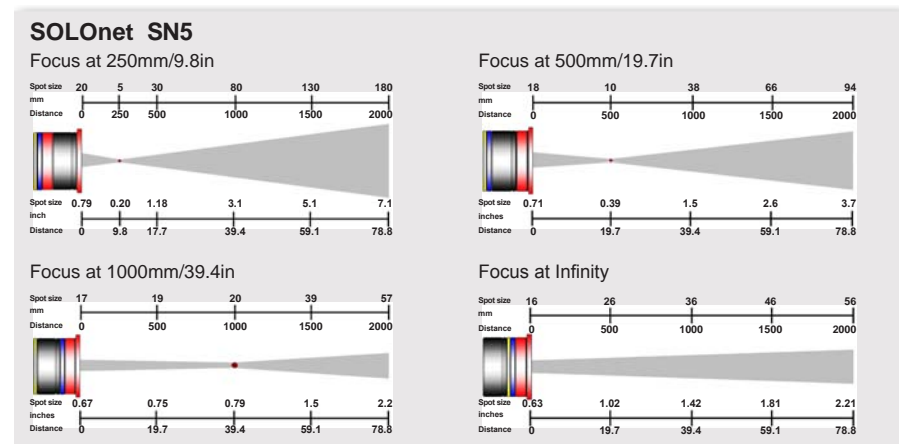
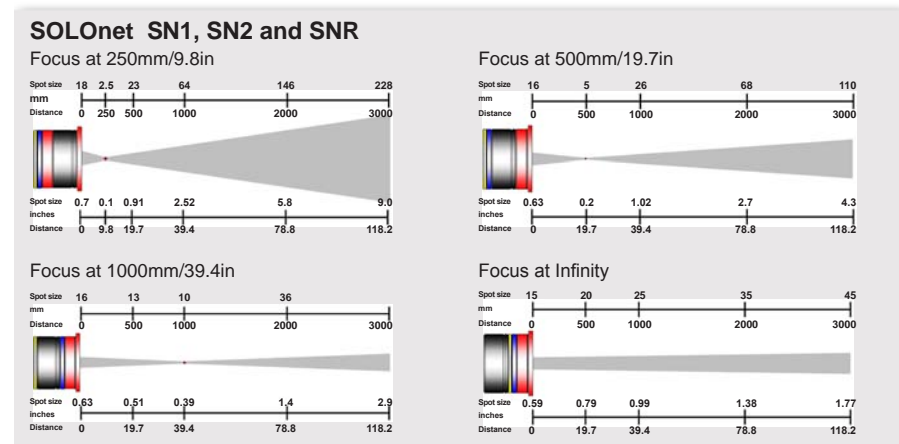

## Thermometer specifications

Model	SN11	SN21	SN51	SNR1
Operating range:	550 to 1750°C/ 1022 to 3182°F	250 to 1300°C/ 392 to 2372°F	200 to 1100°C/ 392 to 2012°F	700 to 1750°C/ 1292 to 3182°F
Specified range:	600 to 1750°C/ 1112 to 3182°F	300 to 1300°C/ 572 to 2372°F	250 to 1100°C/ 482 to 2012°F	750 to 1750°C/ 1382 to 3182°F
Spectral response:	1µm	1.6µm	5µm	1µm ratio
Field of view (95% energy):	100:1	100:1	50:1	100:1
Focusing:	Fixed, user configurable focus: 250mm/9.8in, 500mm/19.7in, 1000mm/39.4in and infinity			
Output:	0 or 4 to 20mA user selectable (isolated 50V)			
Response time (0 to 90%):	10ms	10ms	50ms	10ms
Emissivity:	0.10 to 1.00			
Non greyness:	0.80 to 1.25			
Resolution (mid range):	≤1K			
Stability:	0.2°/°	0.2°/°	0.02%K/K	0.05K/K
Accuracy (absolute):	0.3%K	2K	0.35%K	0.6%K
Time functions:	Peak picker, track and hold, and averager			
Alarm outputs:	Process high, process low, internal temperature, emissivity/NG signal lost, insufficient signal (SNR1 only); rated to 50V d.c., 0.1A non-inductive, NO or NC – software selectable			
Optional sighting:	Laser defining optical axis; class 2, 1mW, 650nm, 120s ON duration, automatic switch-off			
Ambient limits:	5 to 60°C/41 to 140°F specified; 0 to 70°C/32 to 158°F operating			
EMC:	EN 61326:1999 (immunity and emission)			
Sealing:	IP65/NEMA 4X			
Vibration:	3g (10 to 300Hz)			
Power supply:	18 to 30V d.c. (24V d.c. nominal)			
Optional accessories:	Air cooled/purged jacket, water cooled/air purged jacket, air purge and mounting bracket, 1-axis and 2-axis adjustable mounting brackets, 3m, 15m, 25m prewired cable assemblies, Web/Ethernet Interface Unit SN-W/E, d.c. power supply unit, temperature indicator unit LMi			

## Choice of connectivity, web browser and Ethernet interface



SOLOnet thermometers utilise addressable RS485 communications. With this, a thermometer can communicate either directly with an external customer device or with the optional Land SOLOnet Interface Unit SN-W/E.

SN-W/E manages and converts the thermometer's RS485 messaging so that the user can:

- Use the SN-W/E's built-in webserver module to monitor and configure the thermometer using normal web browsing software
- Assign the SN-W/E an IP address, integrate it within the organisational network and communicate with it via Ethernet messaging
- Change the position of the front-panel mounted switch and communicate 'straight through' with addressable RS485

Current and contact-closure I/O is also fitted to each SOLOnet thermometer as standard and this can be accessed directly or via the SN-W/E customer terminals

## More Features

- Flexible communications
- Set measurement in °C or °F
- Set sub-temperature span within the thermometer range (minimum span 50°C/90°F)
- Extended operating range up to 50°C/90°F lower than the thermometer specified range
- Command input to control time functions
- Provide alarm indications, via two hardware relay outputs and digital interface
- Set emissivity or non-greyness value
- Temperature output via both digital serial RS485 interface and current 0 or 4 to 20mA output
- Trigger alignment laser
- Monitor internal ambient temperature
- Provides diagnostic information – input, output and alarm states can be monitored
- User Calibration facility permits the user to apply a correction to the temperature measurement without disturbing the original factory calibration
- Configuration software supplied with each thermometer

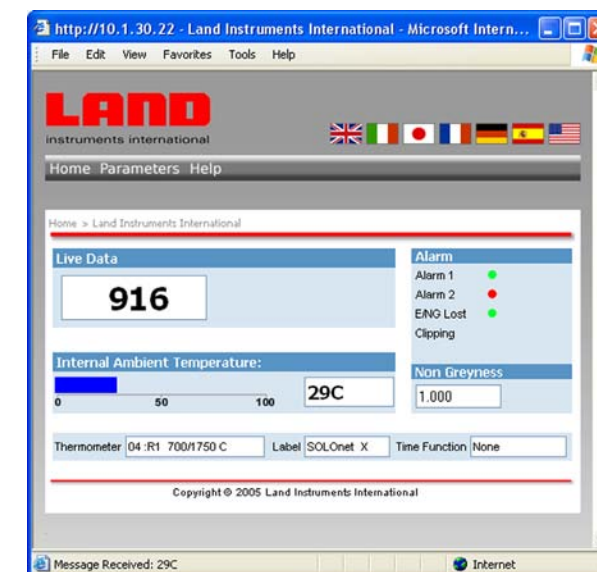

Monitoring screen

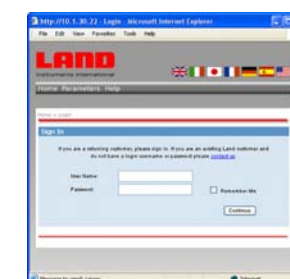

User Log in screen



System set up screen

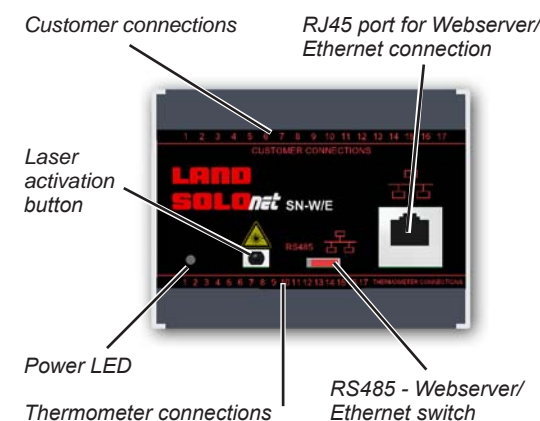

## SN-W/E interface unit specifications

Mounting:	DIN-rail
Dimensions:	100 x 75mm x 110mm/3.94 x 2.95 x 4.33in
Power requirement:	24V d.c. nominal
Ambient operating range:	0 to 70°C/32 to 158°F
Sealing:	IP20/NEMA 1
EMC:	EN 61326:1999