

For fifty years LAND have supplied temperature measuring systems and instruments to many different industries all over the world. Now the world leader in non contact thermometry, our expert advice and support is never far away.



#### WORLDWIDE SUPPORT

In addition to the companies established in the U.S.A., Europe and Japan, LAND is represented by distributors in most of the major industrial countries throughout the world.

Our customers benefit, on a global basis, from practical and expert advice from fully trained technicians who are aware of specific requirements for their country and industry.

#### CALIBRATION

LAND operate an extensive calibration service. All calibrations made are traceable to National Standards. In the UK, LAND can issue a UKAS calibration certificate.

In the U.S.A. a traceable calibration certificate can be issued complying with the National Institute of Standards and Technology (NIST).

LAND also supply a full range of temperature reference sources which are used to verify or re-establish the accuracy of calibration in the field or in the laboratory.

A consultancy service is also available for those companies who wish to establish their own in-house calibration facility.

#### APPLICATIONS

LAND have solved many different temperature measurement problems in a wide variety of industries from food to atomic energy, some of which are listed below:

- Iron & Steel
- Heat Treatment
- Non-ferrous Metals
- Minerals
- Glass
- Petrochemical
- Power & Utilities
- Aerospace
- Electronics
- Pharmaceuticals
- Plastics
- Paper
- Rubber
- Textiles
- Maintenance

For further information or free advice on specific temperature measurement problems within these or any other industry, contact your nearest Land office.

#### PRODUCT ASSURANCE

When you specify LAND products you are assured of receiving a completely pretested, calibrated working product. Each instrument is carefully checked to ensure complete compliance with specification and is fully guaranteed. LAND was the first manufacturer of infrared instruments to successfully obtain ISO 9001 Quality Management System Approval for both design and manufacture of non contact infrared temperature measuring equipment.

 These products with current European directives relating to electromagnetic compatibility and safety (EMC directive 89/336/EEC; Low voltage directive 73/23/EEC).

# LAND

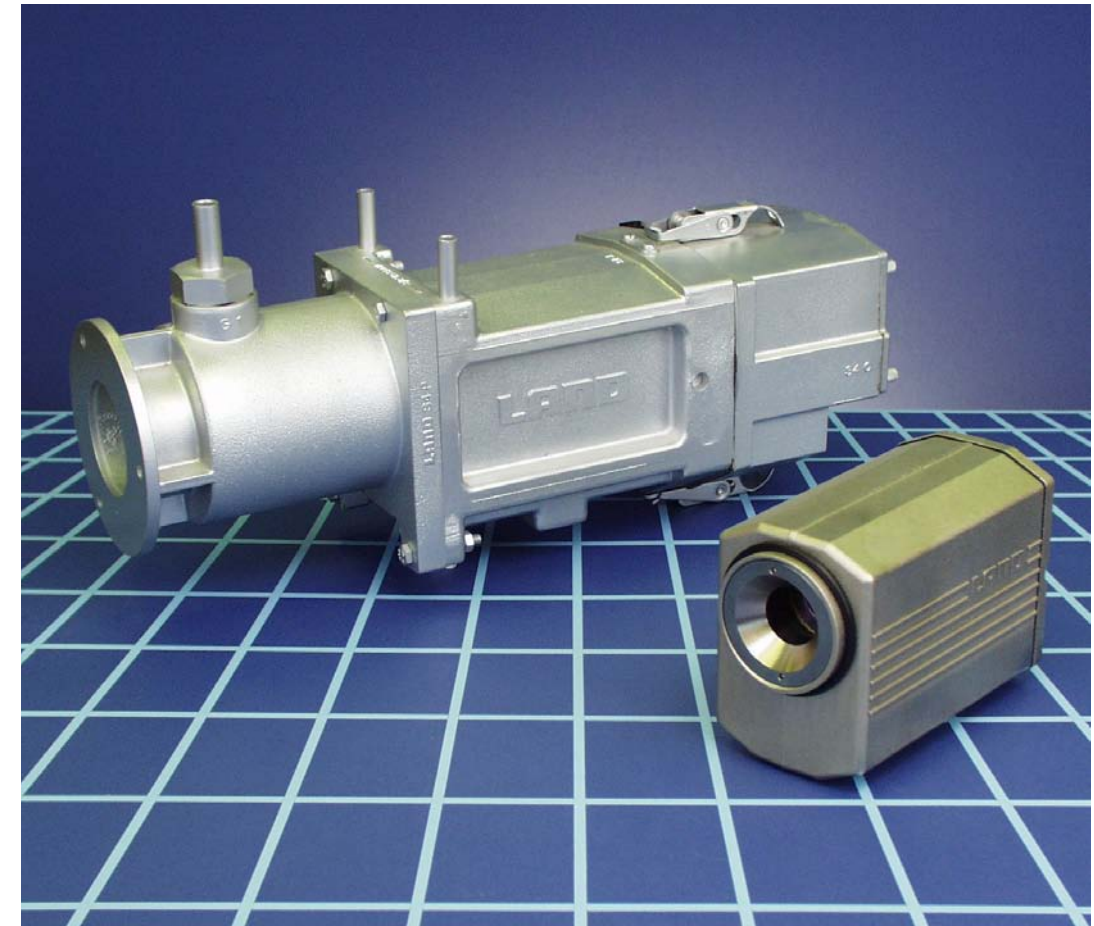

## SYSTEM 4

MOUNTINGS AND  
ACCESSORIES

# LAND

Non-Contact Temperature  
Measurement Solutions

Land Instruments International Ltd • Dronfield S18 1DJ • England  
Email: land.infrared@ametek.co.uk • www.landinst.com • Tel: +44 (0) 1246 417691 • Fax: +44 (0) 1246 410585

AMETEK Land, Inc. • 150 Freeport Rd • Pittsburgh, PA 15238 • U.S.A.  
Email: irsales@ametek.com • www.ametek-land.com • Tel: +1 (412) 826 4444 • Fax: +1 (412) 826 4460

For a full list of international offices, please visit our website.



An AMETEK Company

Applies in the UK

Applies in the USA

An AMETEK Company

# LAND THERMOMETER MOUNTINGS AND ACCESSORIES

The Standard Bodied and Fibroptic range of temperature measurement systems from Land Infrared include a comprehensive range of thermometer mounting and protection accessories to suit any measurement environment. All mountings and accessories enable quick and tool-free installation and removal of the thermometer. The range of accessories can be sub-divided into three groups **INDUSTRIAL**, **NON-HOSTILE** and **LABORATORY**. These groups provide a classification which equate to the given environmental conditions.

## SELECTING MOUNTINGS AND ACCESSORIES

The following information will help determine which specific mountings and accessories are necessary to maintain measurement accuracy and reliability of the thermometer.

### Cooling Jacket - Standard Thermometers

The thermometer cooling and protection jacket provides benefits where there is a requirement for:

- Thermal protection of the thermometer i.e. high ambient temperatures
- Mechanical protection of the thermometer i.e. risk of damage
- Full environmental protection of the thermometer i.e. water or smoke ingress

### End Cap - Standard Thermometers

The End Cap provides benefits where there is a requirement for:

- Full environmental protection of the thermometer electrical connections i.e. water ingress

### Air Purge

The Air Purge clears dust, steam and smoke from the thermometer sight path to ensure accurate temperature measurement. An Air Purge is required to:

- Clear the sight path
- Prevent build-up of debris on the thermometer lens
- Protect the lens from flame or gas impingement

### Mounting Bracket/Plate/Adapter

The range of brackets, plates and adapters are used where there is a need for:

- Fixed, robust installation
- Thermal protection
- Mechanical protection
- Angular adjustment (accurate sighting)

### Sighting Tubes

Sighting Tubes are used for:

- Viewing the target through flame, smoke, fumes etc.

**INDUSTRIAL** For full details of Standard Body INDUSTRIAL Mountings and Accessories refer to pages 4 - 7.

For Fibroptic INDUSTRIAL Mountings and Accessories, refer to pages 12 and 13.

To be used where severe or extreme environmental conditions prevail.

- High or low ambient temperatures
- Smoke, steam, fumes present in the atmosphere i.e. requirement for thermometer purge
- Exposure to exceptional environmental conditions i.e. inside a furnace
- Potential damage from personnel or other equipment

**NON-HOSTILE** For full details of Standard Body NON-HOSTILE Mountings and Accessories refer to pages 8 and 9.

For Fibroptic NON-HOSTILE Mountings and Accessories refer to page 14.

Where the environmental conditions which apply to the measurement application are less severe i.e. Non-Hostile.

- Room temperature operating conditions i.e. none or minimal requirement for thermometer cooling
- Absence of large amounts of smoke, steam, fumes etc. i.e. potential for air purging to maintain accuracy of reading only
- No unusual environmental conditions
- No possibility of damage from personnel or other equipment i.e. no requirement for heavy-duty mountings

**LABORATORY** For full details of Standard Body LABORATORY Mountings and Accessories refer to page 10.

For Fibroptic LABORATORY Mountings and Accessories refer to pages 14 and 15.

No adverse environmental conditions prevail, a requirement for thermometer mounting only.

**AIR SUPPLY SYSTEMS** For full details of AIR SUPPLY SYSTEMS refer to page 15.

Note: Pt N° - Land Part Number code - please specify when inquiring or ordering.

All dimensions are given in inches.

## Thermometer and Detector Module

The thermometer and detector module has two holes on the underside. It will mount directly onto a tripod or the Small Ball Mounting (S4 B); or can be used with the Large Ball Mounting (S4 LB) with the Mounting Adapter (S4 MA); or fixed to a flat surface using the Mounting Plate (S4 MP).

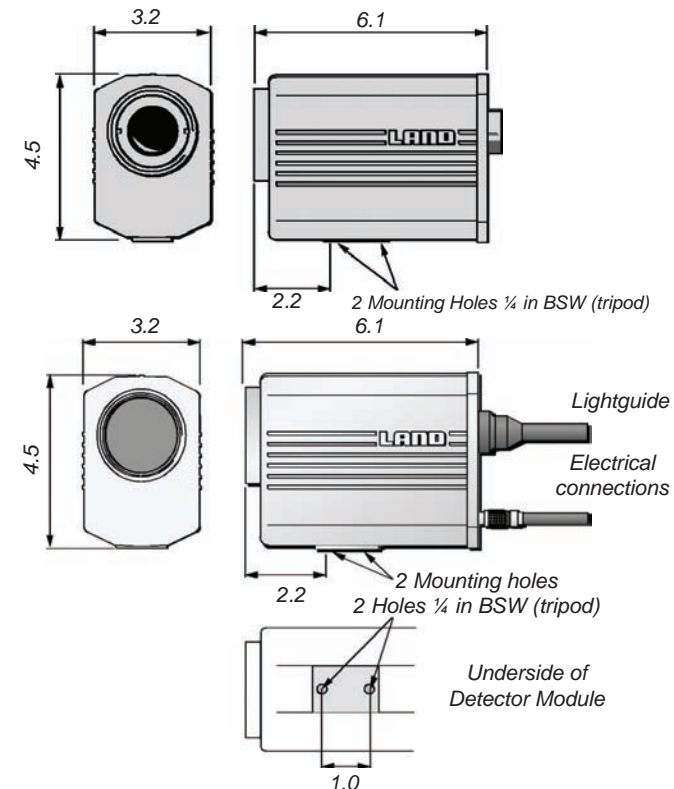

## Mounting Plate S4 MP (Pt N° 029.263)

The mounting plate attaches to the thermometer or detector module using holes C, and mounts to a flat surface using holes A or B. It is supplied with two screws (1/4in BSW, 1/2in long screws, 112.467) to fit the thermometer base.

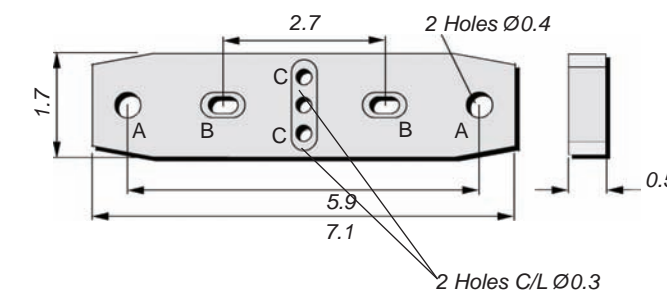

**Mounting Options**  
**A** Mounting holes  
**B** Mounting holes  
**C** Detector module base

## AIR SUPPLY SYSTEMS

Air purges use a stream of air to disperse dust and fumes from the thermometer sight path and to prevent dirt settling on the lens or window.

Clean dry air must be supplied to the purges, and jackets with integral purge and a diffuser.

Any foreign material in the air supply will potentially block the diffuser, reduce the purge efficiency and deposit material on the lens or window.

To achieve the necessary cleanliness standards, the air system should be designed to recommended guidelines. A filter system should be fitted in every air line which feeds a purge.

LAND can supply an automatic drain air filter system with optional low flow alarm for use with correctly engineered compressed air systems.

A relatively clean, dry compressed air supply of 25 to 150 lb/in<sup>2</sup>/1.75 to 10.5 kg/cm<sup>2</sup> is required for use with the system A/A air filter system.

## System A/A (LF and HF)

There are two types of restrictor available; low flow (LF) and high flow (HF). Low Flow (LF) is for use when only purging is required, the high flow (HF) when both purging and cooling are required.

The optional flow alarm detects a low flow rate. This can be linked to a warning device i.e. Klaxon or annunciator lamp to alarm once the flow falls below the required rate.

System A/A/LF (Pt N° 004.449)

System A/A/LF with Low flow alarm (Pt N° 003.939)

System A/A/HF (Pt N° 004.450)

System A/A/HF with Low flow alarm (Pt N° 003.940)

### Fixing Details

The following are pipe dimensions recommended for use with the A/A system:

3/8 in. dia. bore up to 7m/23 ft. long

1/2 in. dia. bore 7m to 27m/23 ft. to 90 ft. long

3/4 in. dia. bore 27m to 210m/90 ft. to 700 ft. long

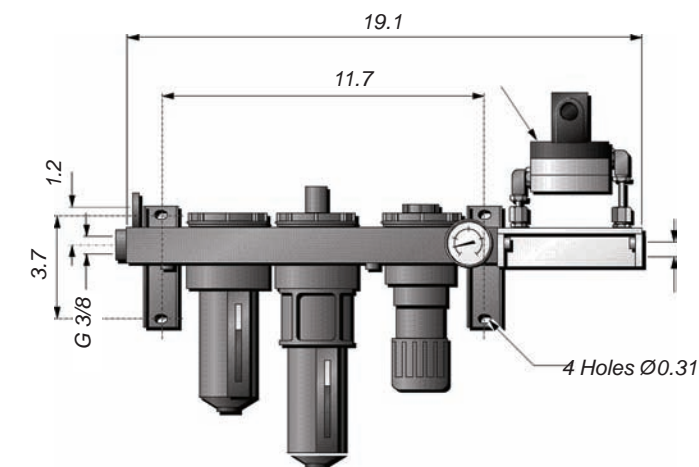

Note: Replacement filters and other spares are available from Land Infrared.

## NON-HOSTILE

### Large Ball Mounting S4 LB (Pt N° 030.566)

The ball mounting is used with the Fibroptic Angle Bracket (S4 FB) to provide adjustable mounting for accurate sighting. Four holes (Ø0.35) permit fixing to a flat surface. A locking handle secures the ball mount at the required orientation.

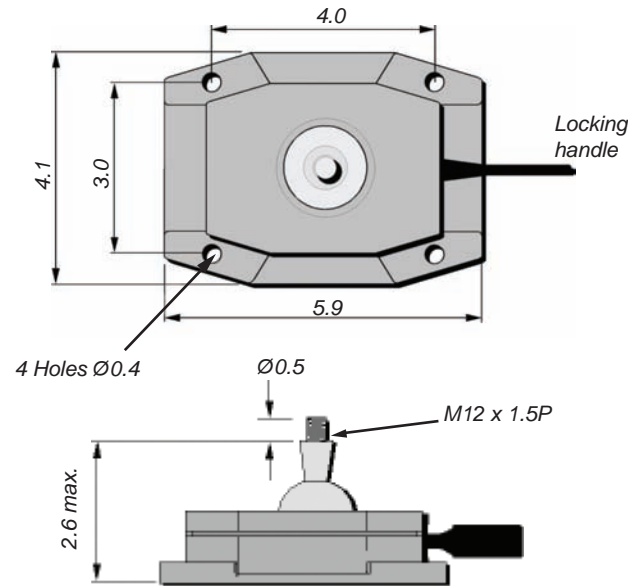

## LABORATORY

### Small Ball Mounting S4 B (Pt N° 150.560)

The S4 B is used with the Fibroptic Adapter (S4 FA) for mounting the optic head only, where accurate sighting is essential. It is identical to a standard tripod mounting.

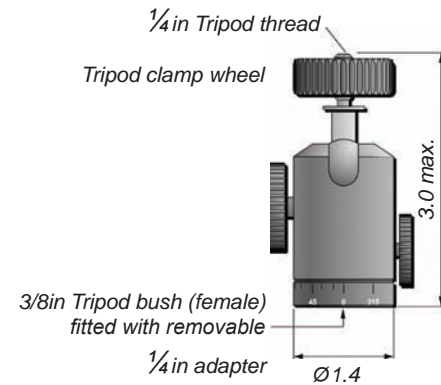

### Fibroptic Angle Bracket S4 FB (Pt N° 029.224)

The Fibroptic Angle Bracket enables the optic head to be mounted either as a stand-alone in applications which require no purging, protection or special mounting considerations; or with the Large Ball Mounting (S4 LB) where accurate sighting is essential.

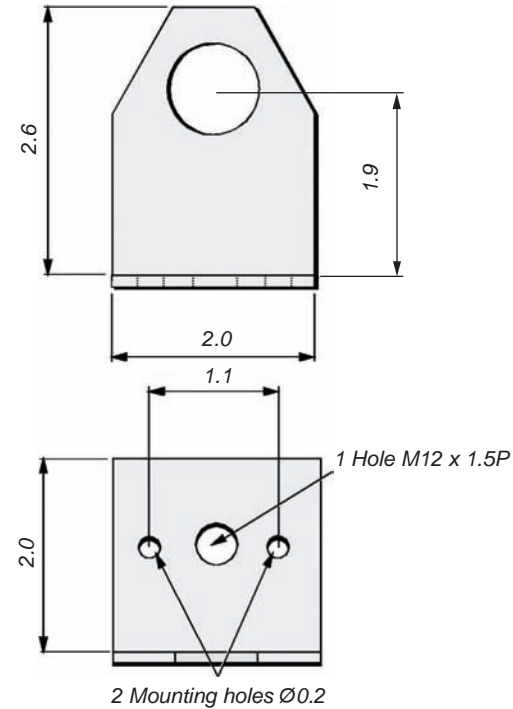

### Fibroptic Adapter S4 FA (Pt N° 029.238)

The Fibroptic Adapter enables the optic head to be mounted as a stand-alone, in applications which require no purging, protection or special mounting considerations. A single 1/4 in thread bolt hole can attach to the Small Ball Mounting (S4 B) or a standard tripod mounting. Two further holes in the base permit mounting to a flat surface.

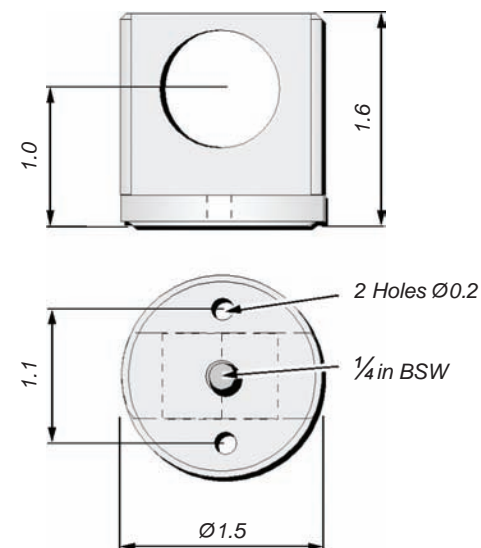

## COMPLETE STANDARD BODIED THERMOMETER SYSTEMS

### INDUSTRIAL

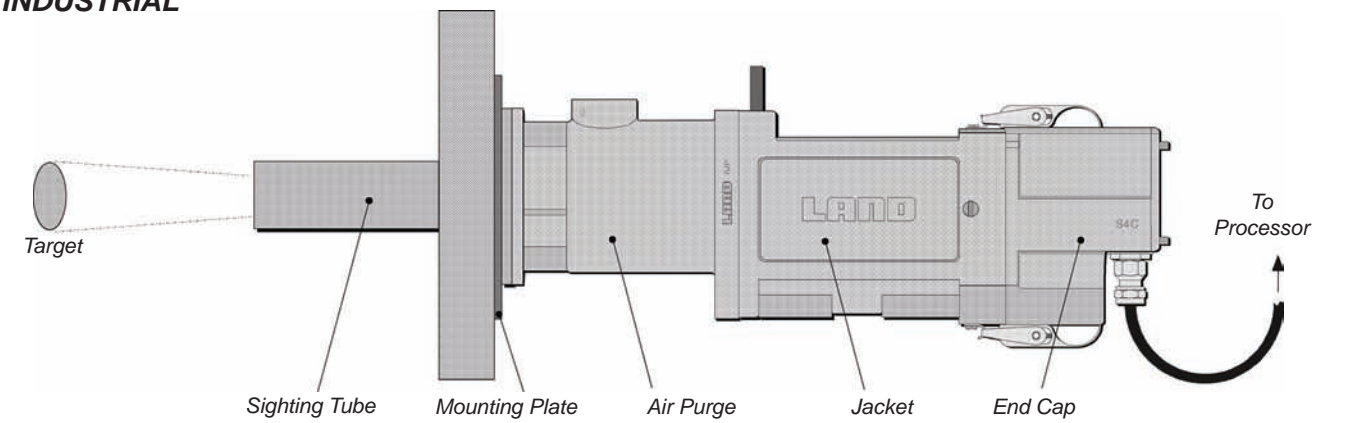

### NON-HOSTILE

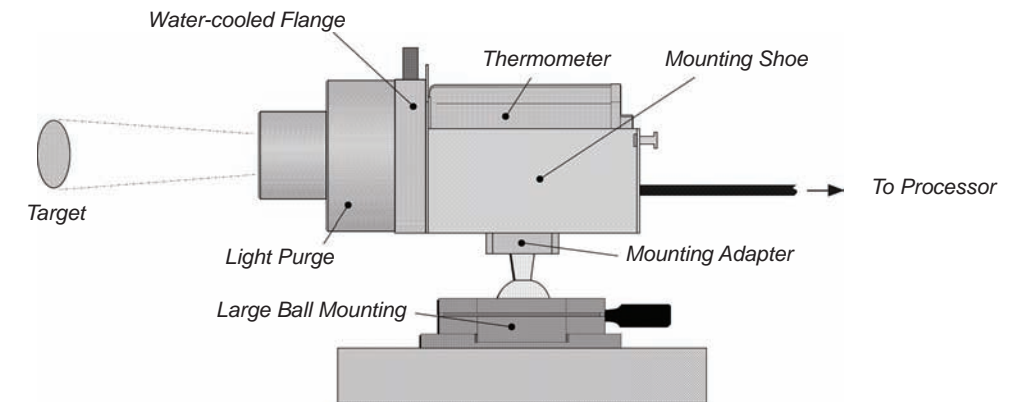

### LABORATORY

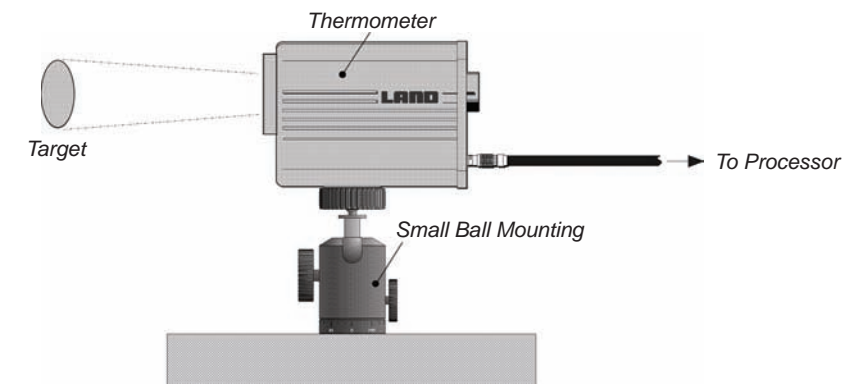

# INDUSTRIAL

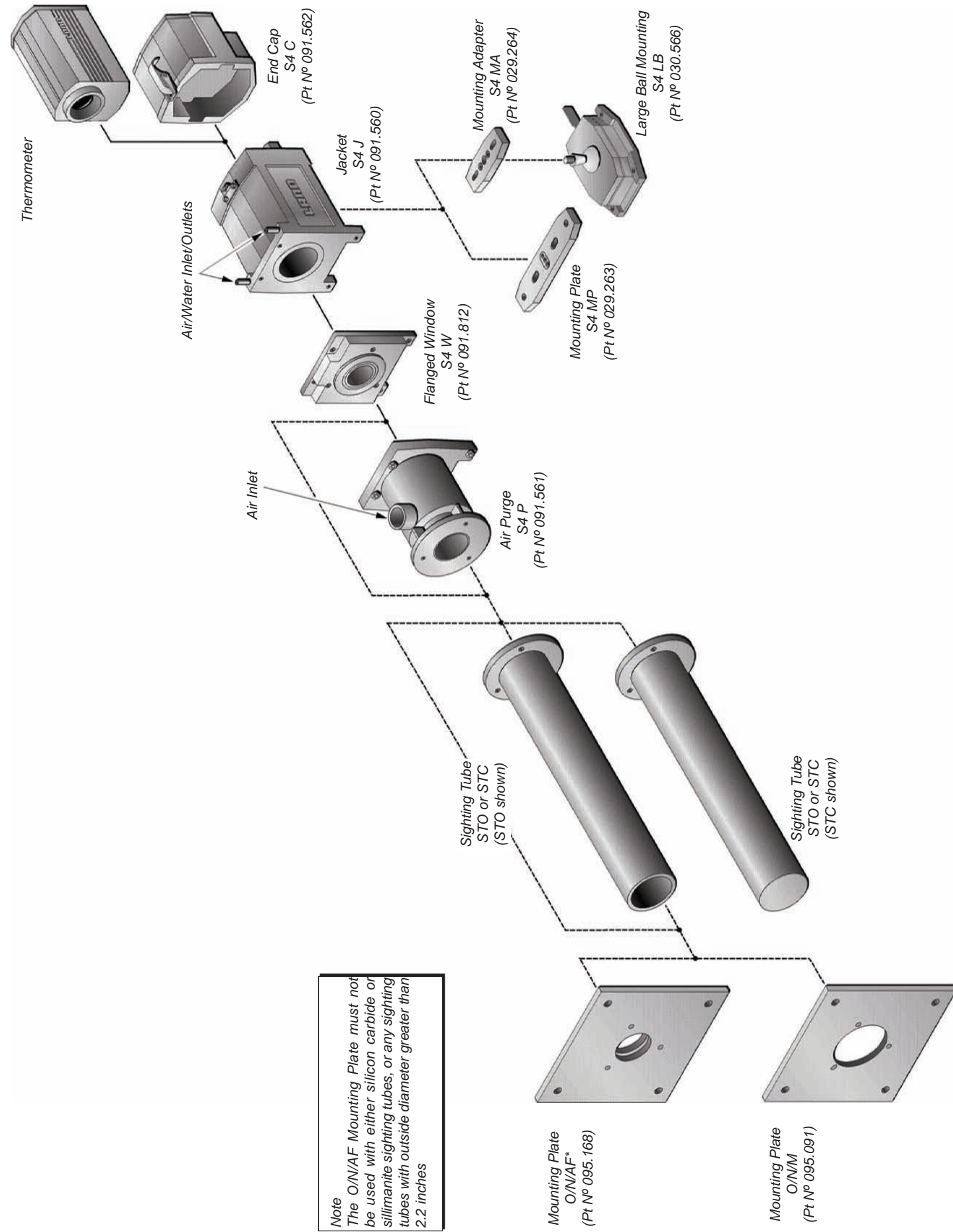

## Large Ball Mounting S4 LB (Pt N° 030.566)

The ball mounting can be used with either the mounting bracket assembly (029.873) or the fiberoptic angle bracket (S4 FB) to provide adjustable mounting for accurate sighting. A locking handle secures the ball mount at the required orientation.

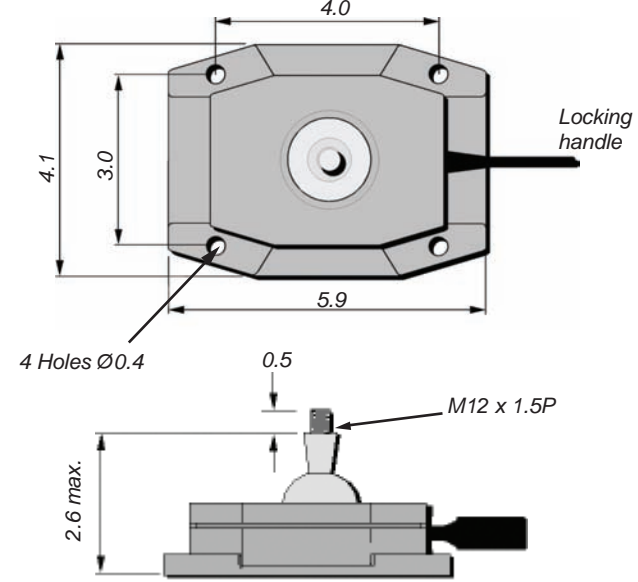

## Hinged Adjustable Mounting Plate (Pt N° 028.745)

The hinged adjustable mounting plate enables the head/adapter/purge assembly to be mounted securely at a fixed location. It has 45° adjustment for accurate sighting onto the target and can be easily adjusted at any time.

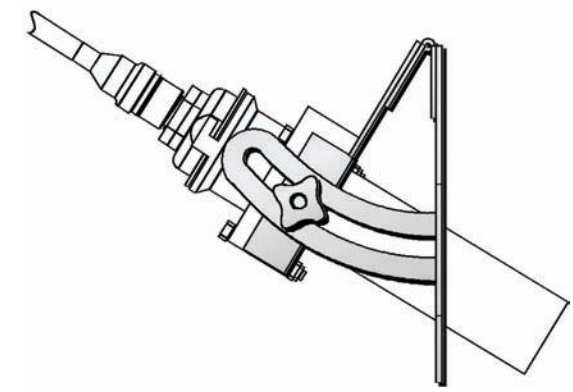
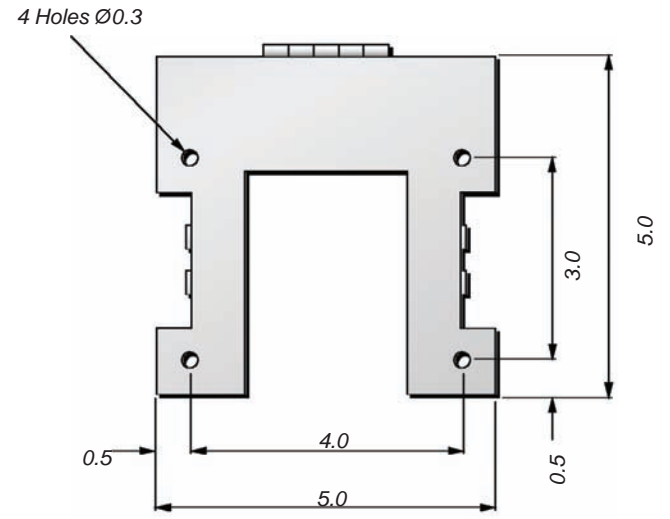

## Quick Release Adapter & Air Purge (Pt N° 029.870)

The air purge is used where a clear sight path has to be maintained, by using the purging air to maintain the lens free from dust, dirt etc. The purge connects to the optic head with a quick-release adapter (supplied) which allows rapid, no tools removal of the optic head for routine maintenance. The purge is secured on the installation using either a mounting adapter or plate (see below).

Air purge flow rate: 60 litre/min (2.12 ft<sup>3</sup>/min)  
Air purge pressure: 0.1 Atmosphere (0.1bar)

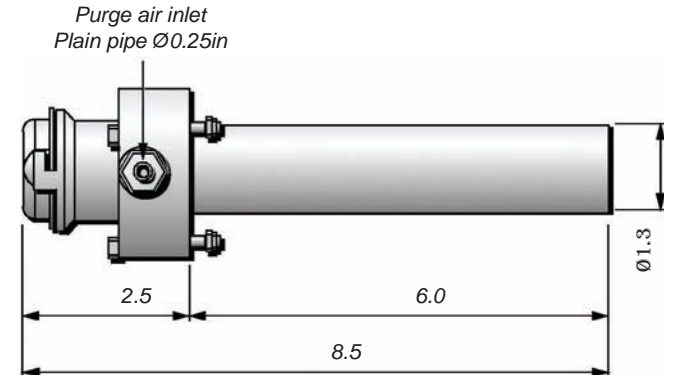

## L&N/Honeywell Adapter (Pt N° 028.825)

This adapter permits the optic head/adapter/purge assembly to be mounted (using the range of holes and slots provided) onto existing thermometer mountings (including competitors) or to a convenient structure for sighting the measurement target area.

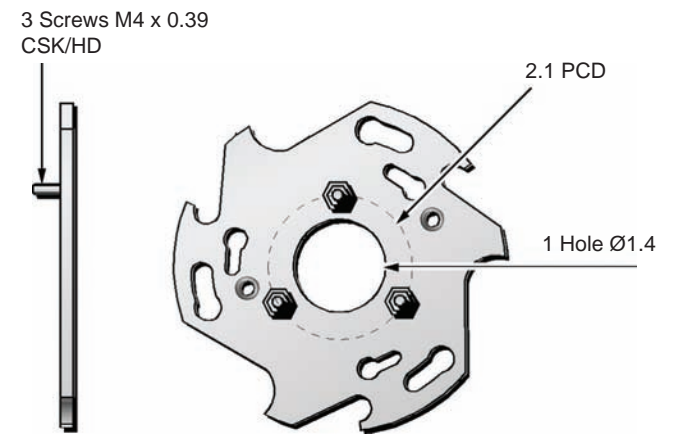

## Quick Release Adapter (Pt N° 029.591)

The quick release adapter allows no tools removal of the optic head from the air purge or mounting for routine maintenance. It permits a System 4 optic head to be mounted onto existing System 3 mountings.



# INDUSTRIAL

## Quick Release Adapter, Air Purge & Adjustable Mounting Flange (Pt N° 029.871)

The adapter, air purge and adjustable mounting flange assembly attaches to the optic head, and provides a mounting using the four holes through the circular plate. Three studs link the main plate to a smaller plate which provide adjustment to ensure accurate alignment on to the target surface; particularly useful when sighting onto a small target. The quick-release adapter which forms an integral part of this assembly allows rapid, no tools removal of the optic head for routine maintenance. Air purge flow rate: 60 litre/min (2.12ft<sup>3</sup>/min), Air purge pressure: 0.1 Atmosphere (0.1bar)

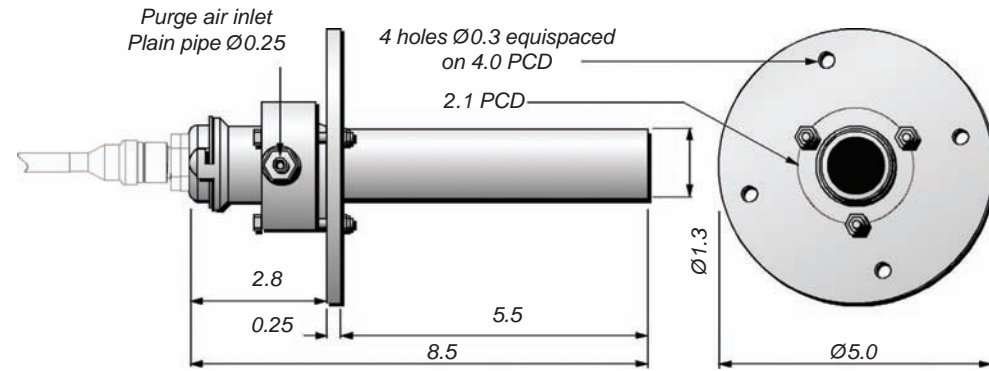

## Adapter, Air Purge & Mounting Plate (Pt N° 029.872)

The adapter, air purge and mounting plate assembly attaches to the optic head, and provides a mounting using the four holes through the circular plate. The quick-release adapter which forms an integral part of this assembly allows rapid, no tools removal of the optic head for routine maintenance. Air purge flow rate: 60 litre/min (2.12ft<sup>3</sup>/min), Air purge pressure: 0.1 Atmosphere (0.1bar)

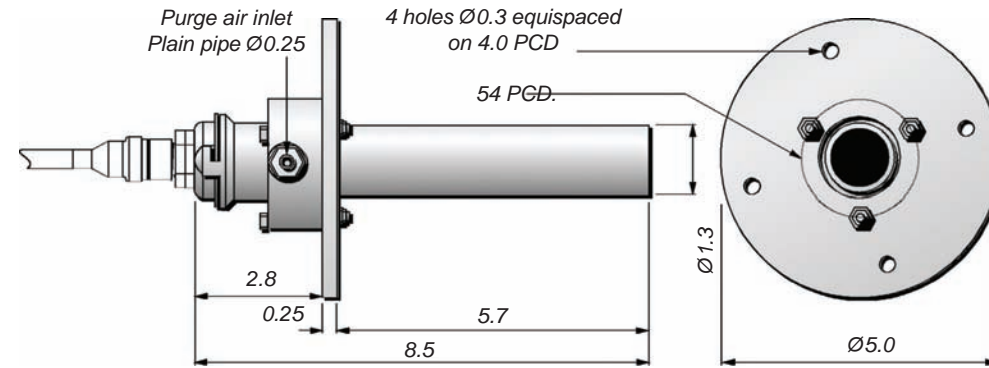

## Adapter, Air Purge & Mounting Bracket (Pt N° 029.873)

The adapter, air purge and mounting bracket assembly attaches to the optic head, and provides mounting using the single hole in the base of the bracket. Alternatively, the bracket will attach to the large ball-mounting (S4 LB) to provide adjustment to ensure accurate alignment on to the target surface; particularly useful when sighting onto a small target. The quick-release adapter which forms an integral part of this assembly allows rapid, no tools removal of the optic head for routine maintenance. Air purge flow rate: 60 litre/min (2.12ft<sup>3</sup>/min), Air purge pressure: 0.1 Atmosphere (0.1bar)

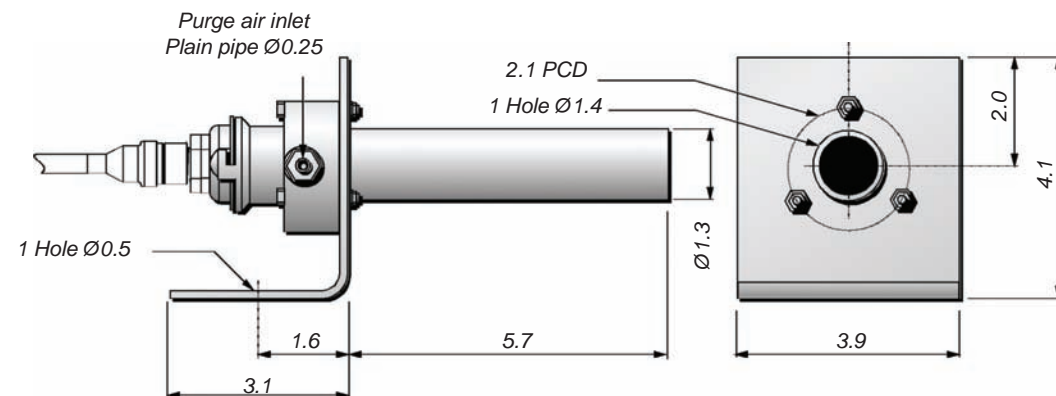

# THERMOMETER COOLING JACKET, END CAP AND PURGE

## End Cap S4 - C (Pt N° 091.562)

The End Cap provides full environmental protection for the electrical connections to the thermometer. Customer connections are made to the terminal strip inside the cap. The pre-wired thermometer connector plug is integral to the cap.

Two Camlock fasteners secure the cap to the thermometer jacket for use in a hostile environment. Weight: 3.42lb

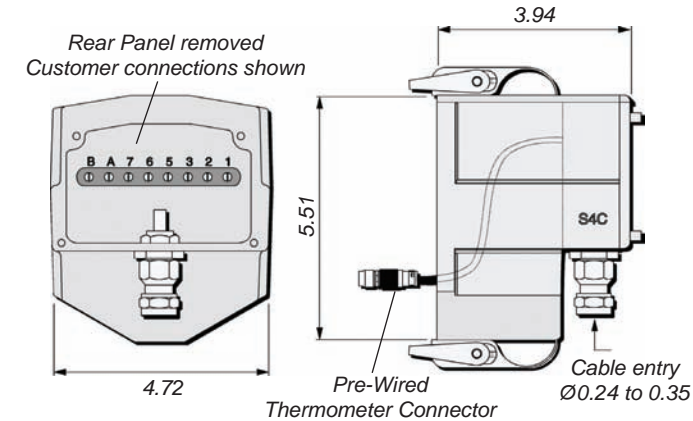

## Thermometer Connector (Pt N° 029.673)

The thermometer connector is normally prewired and terminated in the end cap. A connector prewired to cable must be ordered if the user does not require an end cap.

## Air Purge S4 - P (Pt N° 091.561)

Air purge units use a stream of clean air to keep condensation, dirt and other deposits from the thermometer lens/window. The air stream also helps to disperse steam, fumes or smoke from immediately in front of the thermometer. The units are robust, trouble free and easily fitted between jacket and mounting plate or straight onto the jacket if a universal mounting is used. The only requirement is clean and dry air supply.

Inlet pressure: 350N/m<sup>2</sup> / 3.5mBar (0.05 psi)  
Flow rate: 60 l/min / 2cfm < 2cfm  
Pipe thread: G1 (BS), for fan air supply  
Weight: 3.2lb.

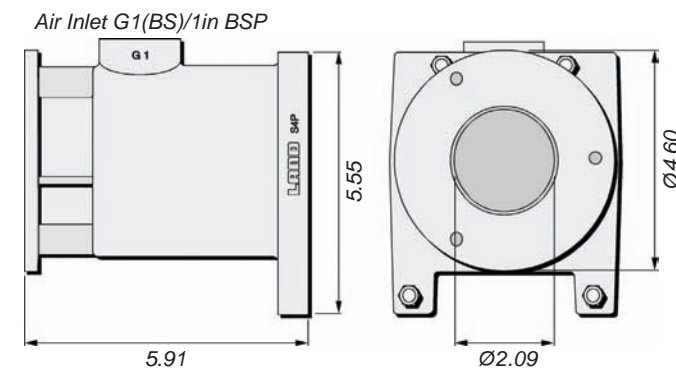

## Cooling Jacket S4 - J (Pt N° 091.560)

The cooling jacket contains an effective air or water cooling facility for use in environments where excessive heat may damage or affect the thermometer. The thermometer fits inside and is held in place by two retaining clips.

Water cooled: Flow  $\leq$  1 l/min / 0.2 Gal/min (exceeding the recommended flow may cause over-cooling leading to condensation problems)  
Air cooled: Flow < 450 l/min / 16 cfm  
Maximum working pressure: 700kNm<sup>2</sup>/7Bar (100psi)  
Plain pipe connections:  $\varnothing$ 0.375  
Weight: 4.85lb

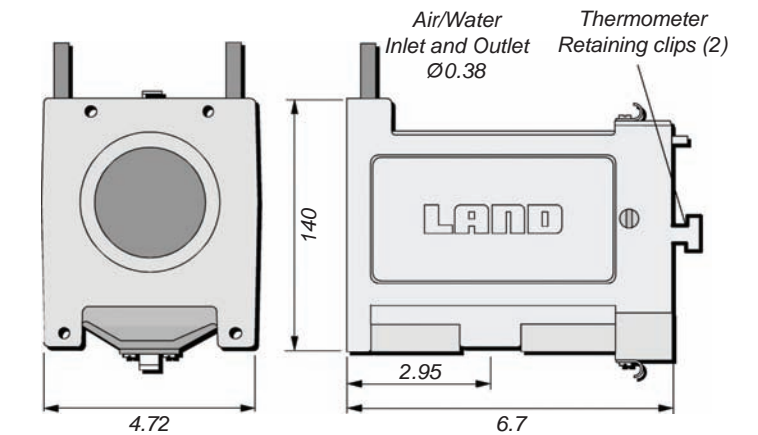

## Mounting holes underside of S4 J Jacket

Two holes (M6 x 1P) in the base of the Cooling Jacket (S4 J) permit mounting directly to a flat surface or to an alternative mounting i.e. S4 MA or MP.

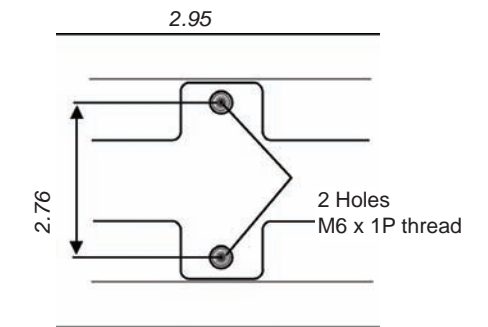

## Assembly

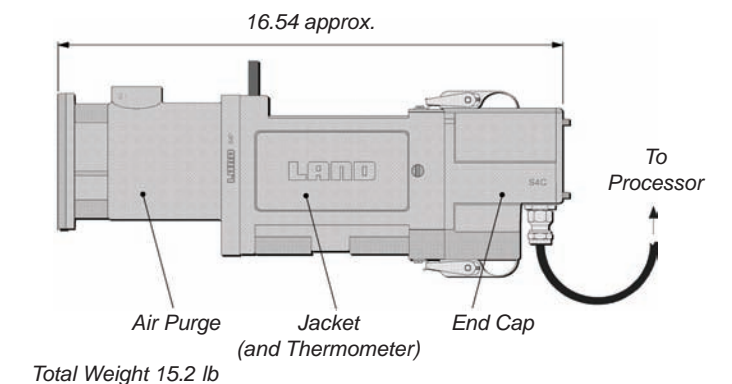

Total Weight 15.2 lb

## THERMOMETER MOUNTINGS AND BRACKETS

### Mounting Plate O/N/M (Pt N° 095.091)

The mounting plate has four fixing holes, three studs for the jacket or purge, and a centre thermometer hole. It is ideal for mounting System 4 thermometer systems. Weight: 8lb.

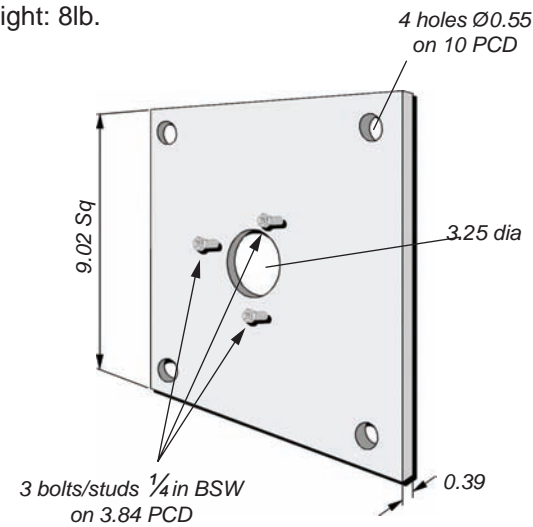

### Adjustable Mounting Plate O/N/AF (Pt N° 095.168)

The jacket or purge fastens to a circular plate, which with the adjustment of four screws can move up to 7.5° with respect to the main plate. For use where accurate sighting is essential. Weight: 11lb.

**This plate is not suitable for use with either silicon carbide or sillimanite sighting tubes.**

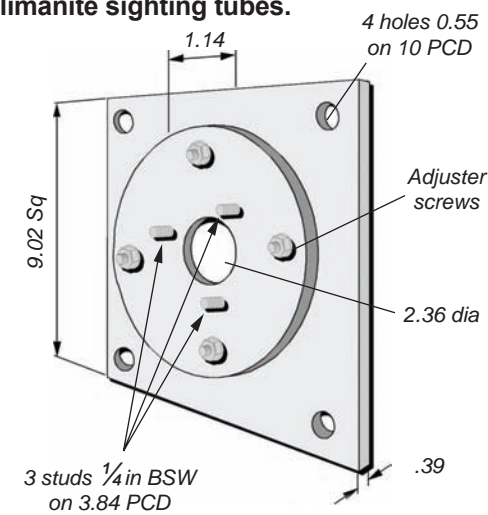

### Mounting Adapter S4 MA (Pt N° 029.264)

When the ball mounting is used with the cooling jacket this adapter provides a stable plate on which to attach the jacket.

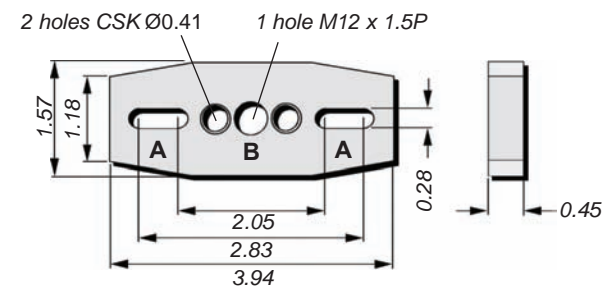

**Mounting Options**  
**A** Jacket (S4 J)  
**B** Large Ball Mount (S4 LB)

### Mounting Plate S4 MP (Pt N° 029.263)

The mounting plate can be used to mount the jacket to a flat surface using holes (A). It has holes at centres identical to those of the jacket (B). Two 1/4 inch BSW, 1/2 inch long screws (112.467) are supplied with the plate to secure it to the jacket.

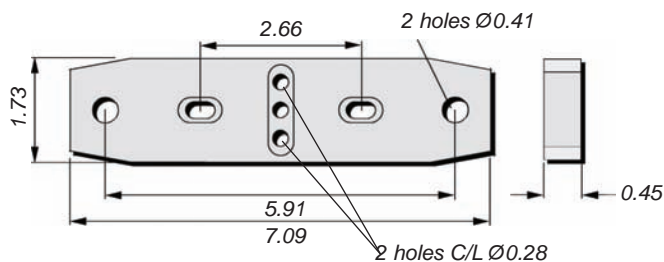

**Mounting Options**  
**A** Mounting Holes  
**B** Jacket (S4 J)

### Large Ball Mounting S4 LB (Pt N° 030.566)

The ball mounting is used with the Mounting adapter (S4 MA). Four holes permit fixing to flat surface. A locking handle secures the ball mount at the required orientation for accurate sighting.

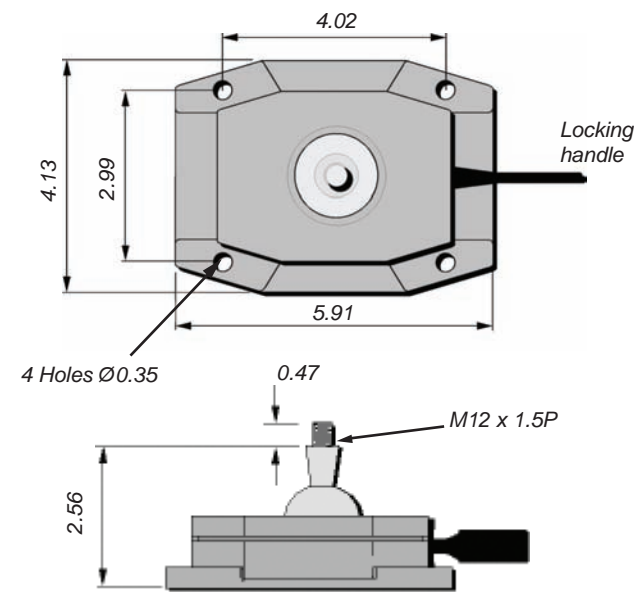

## COMPLETE FIBROPTIC THERMOMETER SYSTEMS

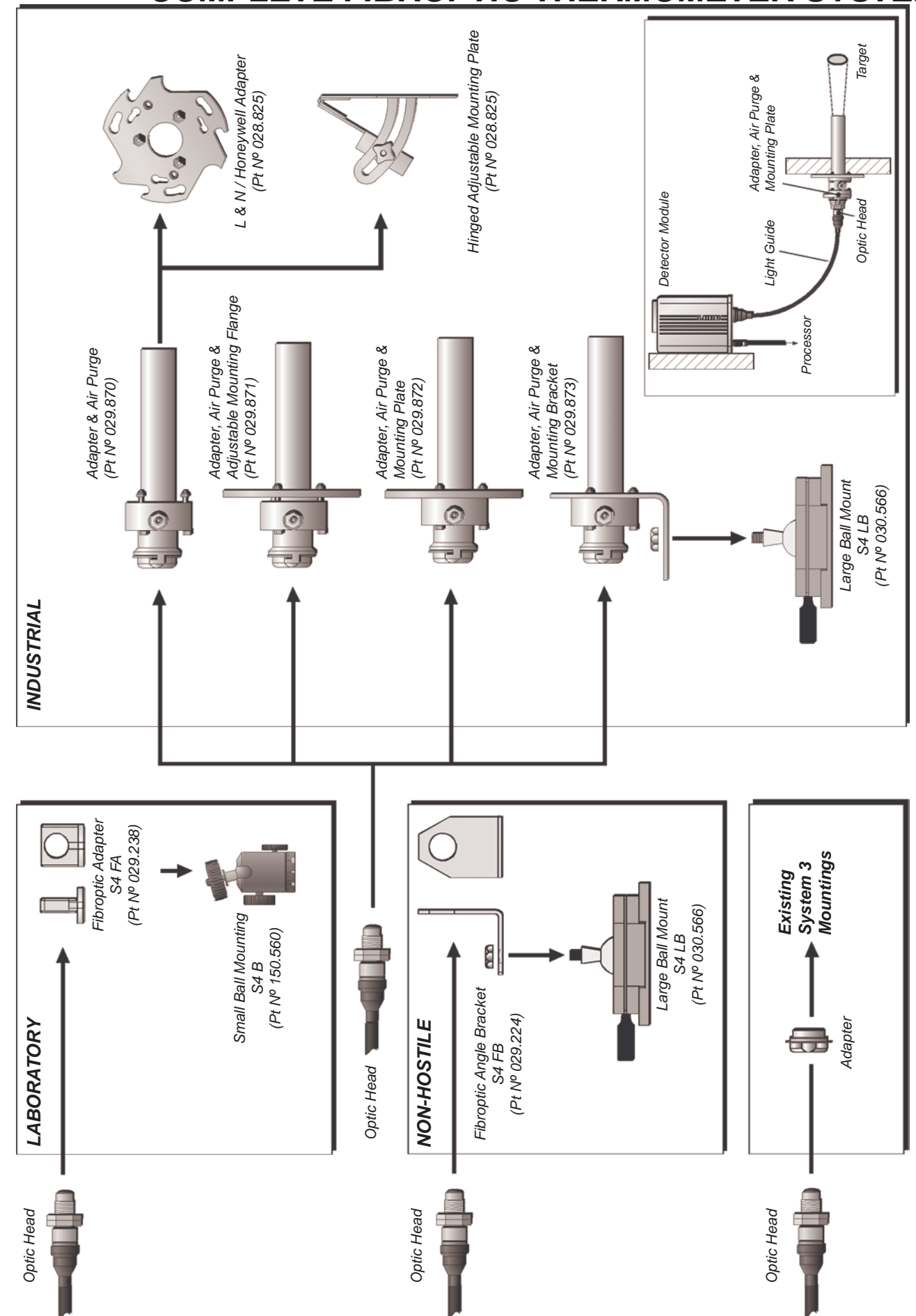

# LABORATORY

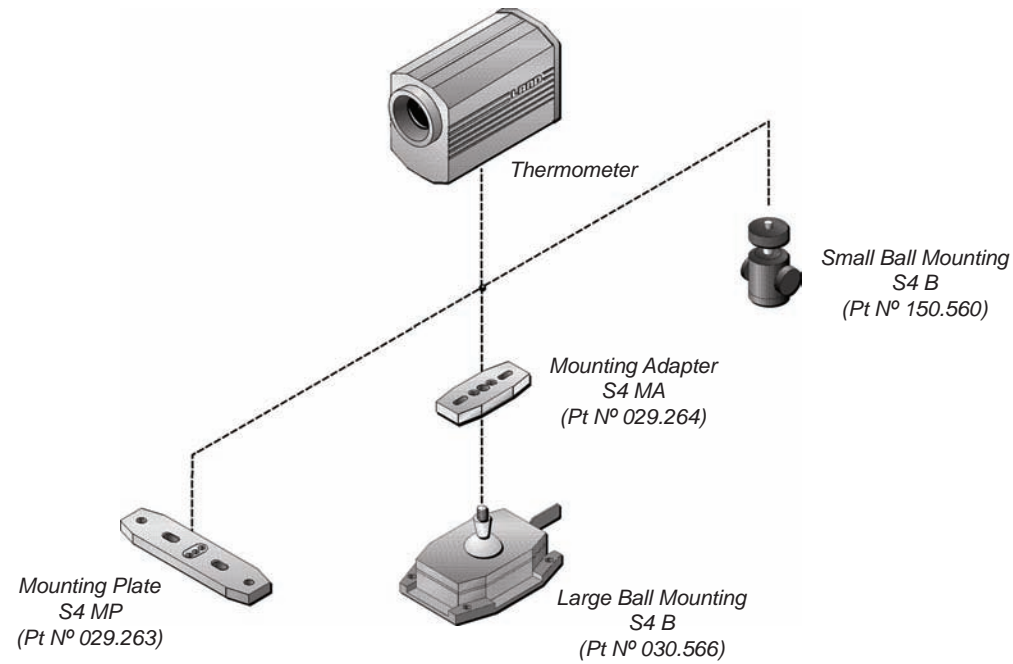

## THERMOMETER MOUNTINGS AND ACCESSORIES

### Mounting Adapter S4 MA (Pt N° 029.264)

When the ball mounting is used with the thermometer this adapter fits to the thermometer base (A) using the screws provided, and couples using the centre hole (B) to the Large Ball Mounting (S4 LB). Two 1/4in BSW, 1/2in long r/head screws (112.467) are supplied with the adapter to secure it to the thermometer.

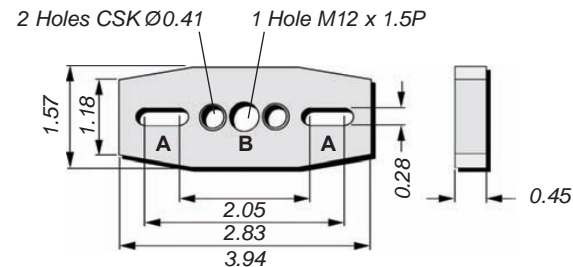

**Mounting Options**  
**A** Jacket  
**B** Large Ball Mount (S4 LB)

### Small Ball Mounting S4 B (Pt N° 150.560)

The S4 B can be used with the thermometer only, for accurate sighting. It is identical to a standard tripod mounting.

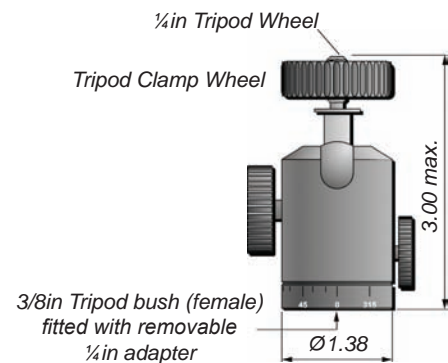

### Large Ball Mounting S4 LB (Pt N° 030.566)

The large ball mounting attaches to the thermometer using the mounting adapter (S4 MA using Mounting Option B). Four holes (Ø0.35) permit fixing to a flat surface. A locking handle secures the ball mount at the required orientation for accurate sighting.

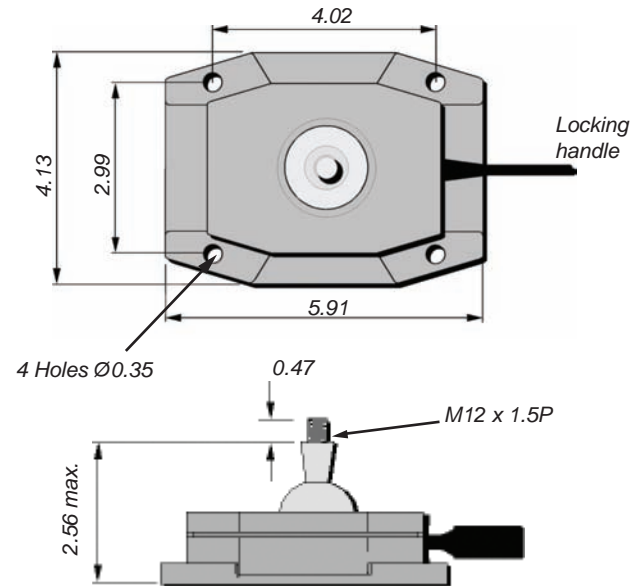

## WINDOW ASSEMBLY AND SIGHTING TUBES

### Sighting Tubes

Sighting tubes are made from metal or refractory materials and are either open ended (Type STO) or closed (Type STC).

Type STO tubes are used when viewing a solid target through flame, smoke, fumes etc. The closed end of the type STC tube is used as the target. A thermometer used with an STC tube can replace a sheathed thermocouple.

To attach the sighting tubes to a mounting plate a steel adapter (Type STA) is cemented into refractory sighting tubes. The STA is drilled to fit the studs on the mounting plate (O/N/M).

Replacement Sighting Tubes can be purchased without the STA adapter fitted. Contact Land Infrared for details.

There are 3 types of tube material with varying lengths. For exact dimensions and ordering references please refer to the table adjacent.

### Silicon Carbide Tubes (STO & STC)

These are either open ended or closed, and can be used in temperatures up to 2700°F/1500°C. They have high mechanical strength, good resistance to thermal shock and very high thermal conductivity.

### Sillimanite Tubes (STO only)

These are suitable for use in temperatures up to 2800°F/1550°C and are fairly resistant to thermal shock. Sillimanite liner tubes are also available.

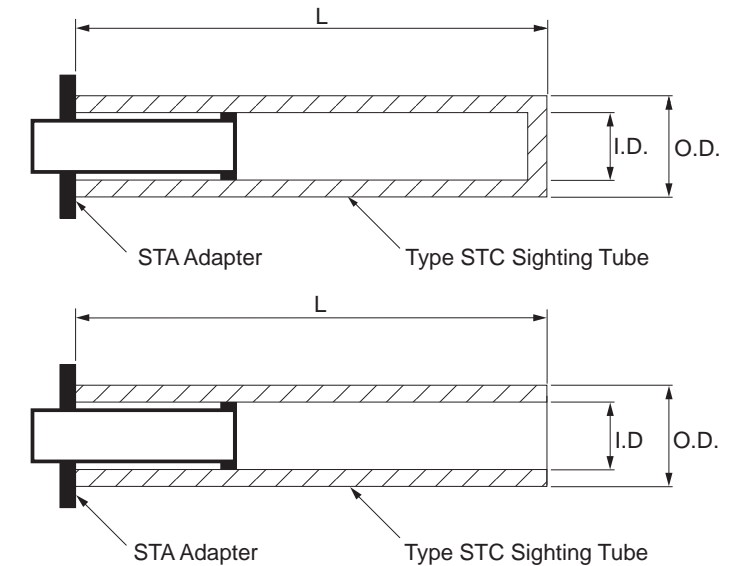

### Stainless Steel Tubes

A low temperature tube for use up to a maximum of 800°C. The exact temperature will depend upon length and operating conditions. Used mainly to protect the thermometer window from physical damage and to direct purge air along the sight path. Stainless Steel sighting tubes come complete with own type F adapter.

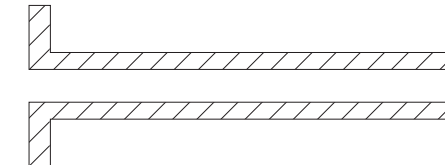

### Sighting Tube Information

Type	Dimensions in			Adapter Type	Part N°
	L	OD	ID		
Silicon Carbide STC	450	76	64	STA	091.410
	600	76	64	STA	091.411
	750	76	64	STA	091.412
	900	76	64	STA	091.413
	1050	76	64	STA	091.414
Silicon Carbide STO	450	76	64	STA	091.415
	600	76	64	STA	091.416
	750	76	64	STA	091.417
	900	76	64	STA	091.418
	1050	76	64	STA	091.419
Sillimanite STO	600	70	2.4	STA	091.420
	750	70	2.4	STA	091.421
	900	70	2.4	STA	091.422
	1050	70	2.4	STA	091.423
	1200	70	2.4	STA	091.424
Sillimanite liner tubes	355	95	3.2	-	118.270
	510	95	3.2	-	118.271
Stainless Steel FS6	150	57	54	F	091.458
	910	57	54	F	N/S

### Window Assembly S4 W (Pt N° 091.812)

The Window Assembly is required for use on pressure vessels, vacuum furnaces and other applications where controlled atmospheres are encountered. Refer to Land Infrared for suitability in a particular application.

Two versions are available:

S4 W (Quartz) Pt N° 091.812  
 For System 4 M1, M2, M4 thermometers and UNO U1, U2, U4 thermometers

S4 W (Fluorite) Pt N° 092.519  
 For System 4 M5, M6, M7 thermometers and UNO U5 thermometers

Replacement seals Pt N° 001.431

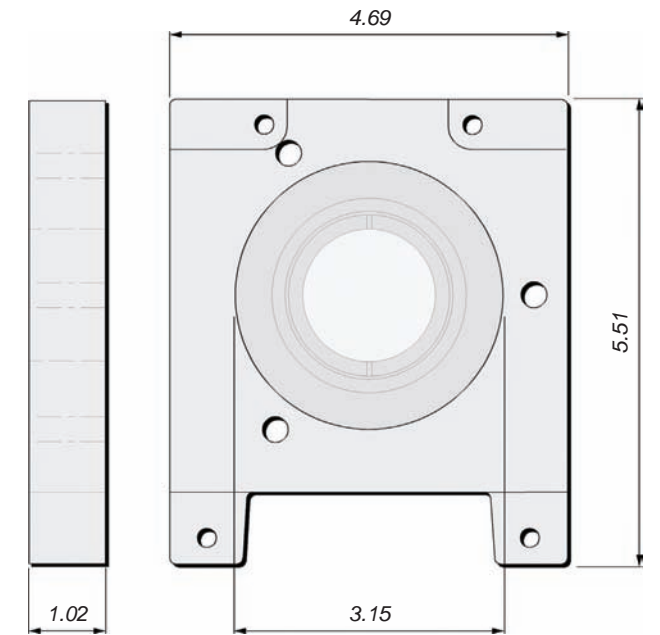

# NON - HOSTILE

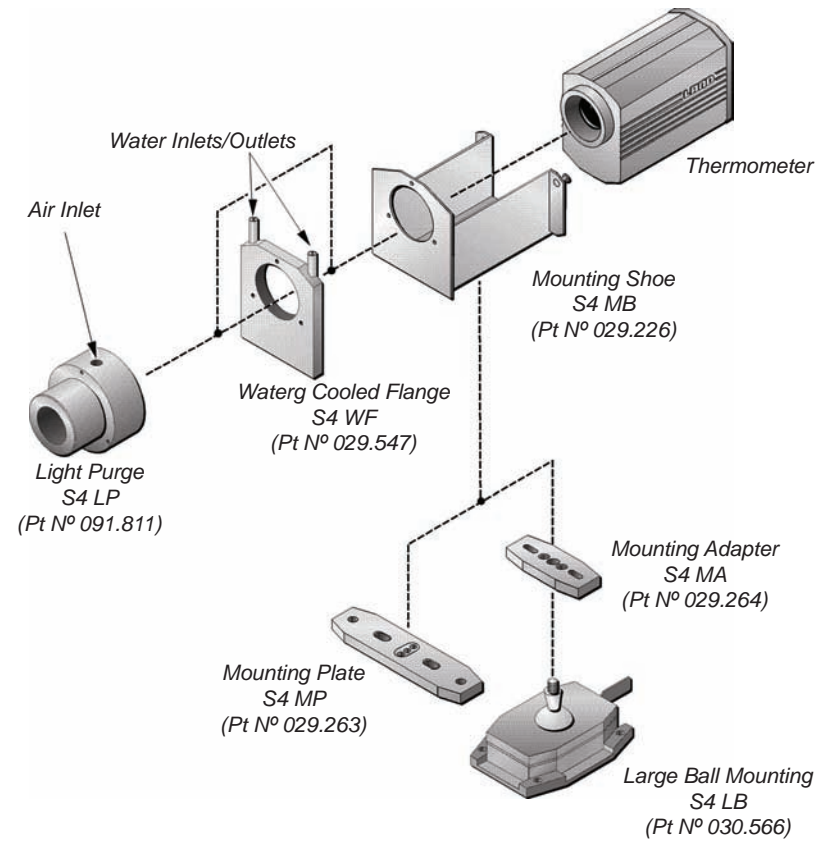

## THERMOMETER MOUNTINGS AND ACCESSORIES

### Mounting Shoe S4 MB (Pt N° 029.226)

The thermometer is held inside the Mounting Shoe using retaining clips similar to those on the S4 J jacket. The holes on the front permit mounting of the S4 LP purge or S4 WF flange.

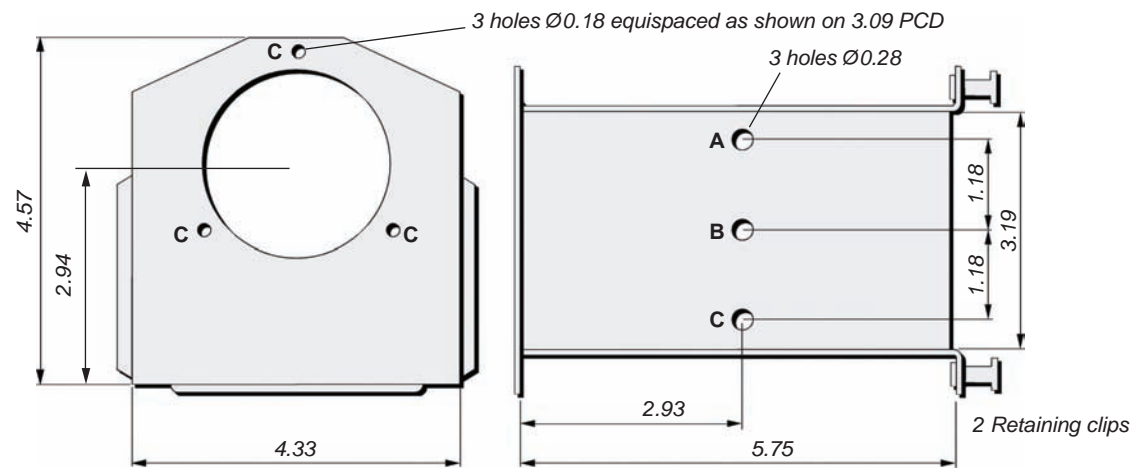

- Mounting Options**
- A Mounting Plate (S4 MP) / Mounting Adapter (S4 MA)
  - B Thermometer Base (To secure only)
  - C Water Cooled Flange (S4 WF) / Light Purge (S4 LP)

### Mounting Adapter S4 MA (Pt N° 029.264)

When the ball mounting is used with the mounting shoe (S4 MB), this adapter provides a stable plate on which to attach the shoe.

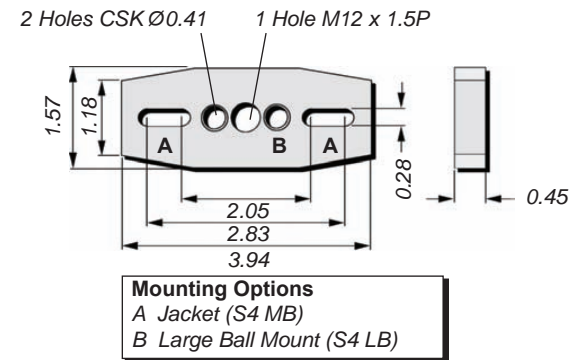

### Large Ball Mounting S4 LB (Pt N° 030.566)

The large ball mounting attaches to the thermometer using the mounting adapter (S4 MA using Mounting Option B). Four holes (Ø0.9) permit fixing to a flat surface. A locking handle secures the ball mount at the required orientation for accurate sighting.

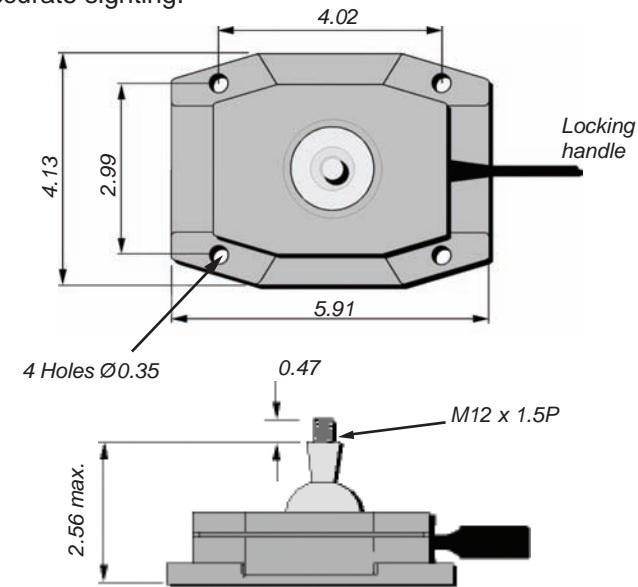

### Mounting Plate S4 MP (Pt N° 029.263)

The mounting plate can be used to mount the shoe to a flat surface. It has three sets of mounting holes as specified below. Two 1/4in BSW, 1/2in long screws (112.467) are supplied with the plate to secure it to the shoe.

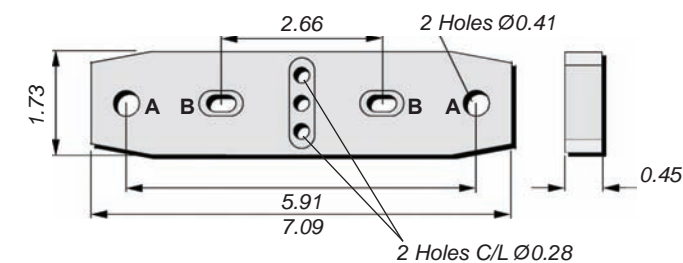

- Mounting Options**
- A Mounting Holes
  - B Jacket (S4 MB)

### Water cooled flange S4 WF (Pt. No. 029.547)

Some applications do not require the strong physical protection and high efficiency cooling of the S4 J jacket, but some cooling may still be necessary to protect the thermometer. In these circumstances the water-cooled flange is recommended. It is mounted to the front face of the mounting shoe, and will ensure that the internal temperature of the thermometer does not exceed the recommended operating temperature upper limit. Water flow: <1 l/min / 13 Gal/hr Pipe connections: Ø0.375

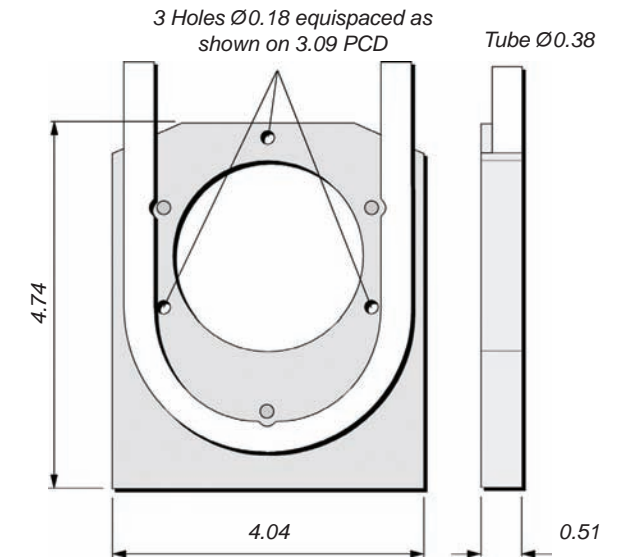

### Light Purge S4 LP (Pt N° 091.811)

This small, highly efficient purge attaches to the mounting shoe (S4 MB) and is used to keep the thermometer lens/window clean.

Inlet pressure: 3750N/m<sup>2</sup>  
Flow rate: 140 l/min  
Hole: G 1/4 (1/4in BSP)

