

Specifications

LAND

FTI-E Thermal Imager	
Measurement range	600 to 1600 °C / 1112 to 2912 °F
Spectral response	nominal 3.9 μm
Frame rate	30 frames per second
Image pixels	384 x 288
Detector type	Uncooled amorphous silicon focal plane array
System measurement accuracy	±1%
System thermal resolution (rms value)	< 0.3 °C / < 0.54 °F
Ambient temperature range	5 to 50 °C / 40 to 120 °F
Sealing	IP 65 / NEMA 4
Vibration	0.5mm, 10 to 60 Hz; 3g, 60 to 300 Hz
CE Certification	EN 61326: 1999 B
Borescope	
Field of View (Horizontal)	30° or 60°
Probe Length	588.5 mm / 23"
Probe Diameter	88.9 mm / 3.5"
Flange	DN 100 PN 16 Other flange options available on request
Dimensions (overall) h x w x l	258 x 269 x 905 mm / 10" x 11" x 36"
Weight	32.5 kg / 72 lb
Maximum Probe Temperature	1200 °C / 2192 °F
Sealing	IP 67 / NEMA 4

Thermal Imaging for Continuous Process Monitoring and Quality Control

Thermal Imaging Solutions for Furnaces & Boilers

Distance from object	Borescope 30 0.5 m min. focus Field of View 30° x 22.5°		Borescope 60 0.5 m min. focus Field of View 60° x 45°	
	Target Area	Pixel Area	Target Area	Pixel Area
1 m	0.54 x 0.40 m	1.4 mm	1.15 x 0.83 m	3.6 mm
5 m	2.68 x 1.99 m	6.9 mm	5.77 x 4.14 m	18.0 mm
10 m	5.36 x 3.98 m	13.8 mm	11.55 x 8.28 m	36.1 mm
15 m	8.04 x 5.97 m	20.7 mm	17.32 x 12.43 m	54.1 mm
20 m	10.72 x 7.96 m	27.6 mm	23.09 x 16.57 m	72.2 mm
Distance from object	19" min. focus Field of View 30° x 22.5°		19" min. focus Field of View 60° x 45°	
	Target Area	Pixel Area	Target Area	Pixel Area
3 ft	1.61 x 1.19 ft	0.050"	3.46 x 2.49 ft	0.130"
15 ft	8.04 x 5.97 ft	0.249"	17.32 x 12.43 ft	0.650"
30 ft	16.08 x 11.93 ft	0.497"	34.65 x 24.85 ft	1.299"
40 ft	21.44 x 15.94 ft	0.663"	46.19 x 33.14 ft	1.732"
60 ft	32.15 x 23.87 ft	0.997"	69.28 x 49.71 ft	2.598"

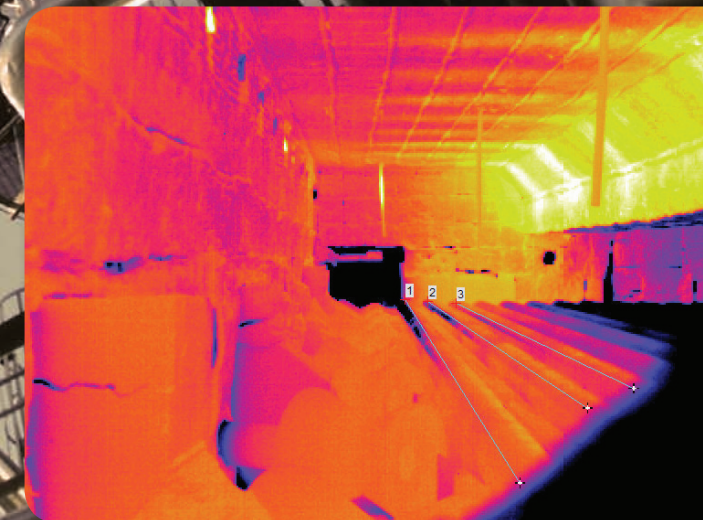

LAND

Land Instruments International Ltd • Dronfield S18 1DJ • England
Email: land.infrared@ametek.co.uk • www.landinst.com • Tel: +44 (0) 1246 417691 • Fax: +44 (0) 1246 410585

AMETEK Land, Inc. • 150 Freeport Rd • Pittsburgh, PA 15238 • U.S.A.
Email: irsales@ametek.com • www.ametek-land.com • Tel: +1 (412) 826 4444 • Fax: +1 (412) 826 4460

For a full list of international offices, please visit our website.



An AMETEK Company

Applies in the UK

Applies in the USA

An AMETEK Company

When thermal imaging inside refractory lined furnaces or boilers is required, the plant operator is required to cut large openings in the refractory to enable viewing of the critical area. This can cause significant wasted energy from heat loss through the opening and can be difficult to keep the opening free from debris.

With the introduction of the FTI-Eb BoreScope, it is possible to use the proven technology of the LAND FTI-E 391 thermal imager to accurately profile the temperature of the entire furnace with only a small opening in the wall.

Features & Benefits

- Wide angle imaging inside the vessel to maximize coverage of the products
- High performance water cooling system with low water flow requirements even in the highest temperature furnaces
- Integrated air purge to keep the optical system clear of debris, while consuming minimal instrument air
- Optional Auto-retraction mechanism to protect the imager should the water cooling or air purge supply fail

Intelligent Design

The FTI-E Thermal Imaging camera is an integral part of the LAND intelligent imaging solution, and is complemented by an extensive range of dedicated system accessories.

LAND Image Processing Software

On-line system providing flexible, application specific thermal analysis

FTI-E Control Processors

Optional industrial processor providing local process control, configuration and process visualization

Industrial Housing

Designed to protect the imager in even the harshest of operating environments and ensures reliable continuous operation

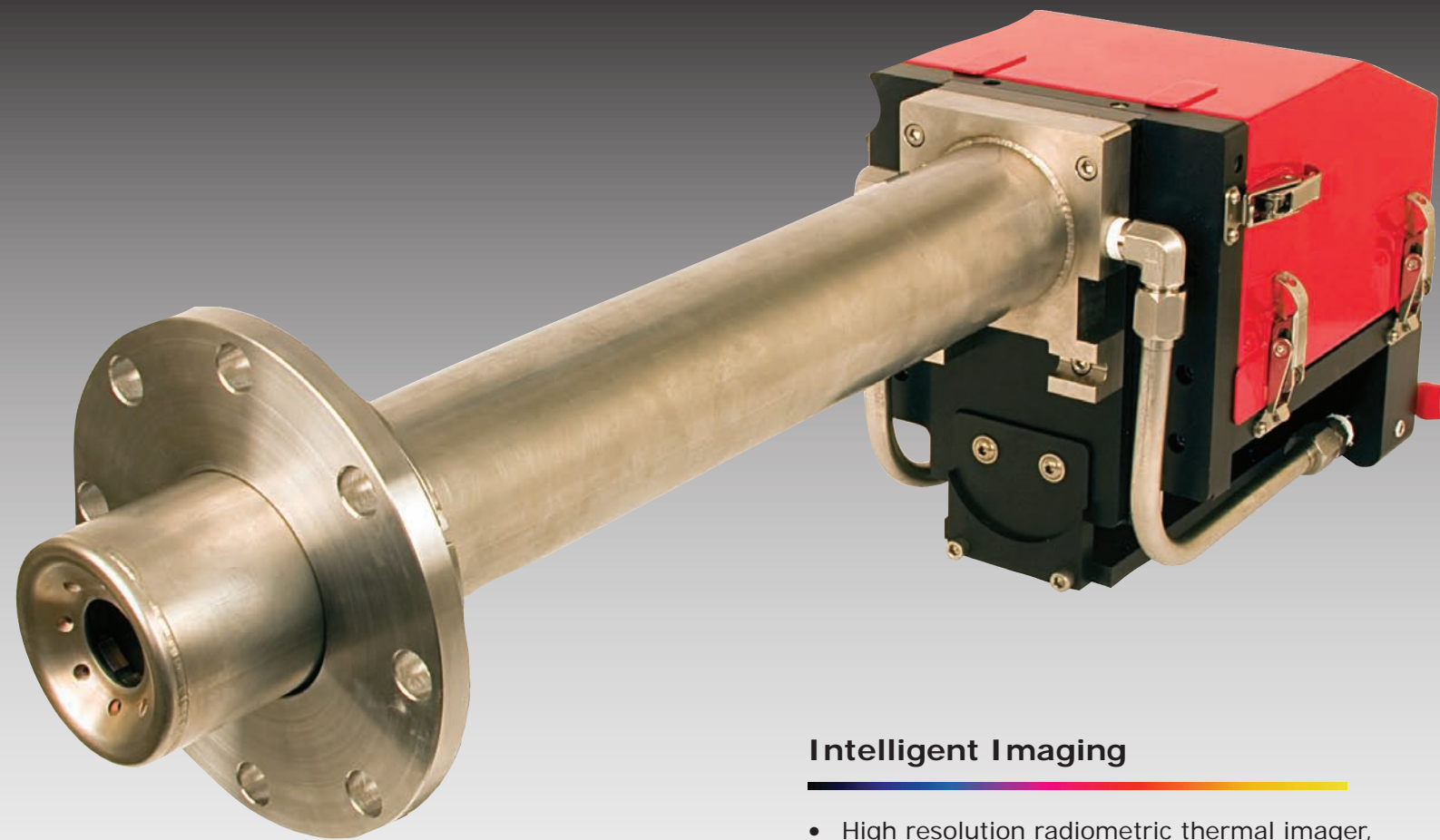

Typical Applications

- Reheat furnace
- Tube furnaces
- Boilers
- Incinerators



Intelligent Imaging

- High resolution radiometric thermal imager, giving detailed temperature information transmitted via a high speed digital connection
- Accurate temperature measurement, enabling optimum process control from over 110,000 individual temperature points
- Simple installation and ease of use, minimizes cost and complexity
- Designed for harsh industrial environments, ensuring ultimate measurement reliability and availability

BoreScope System Schematic (Top View)

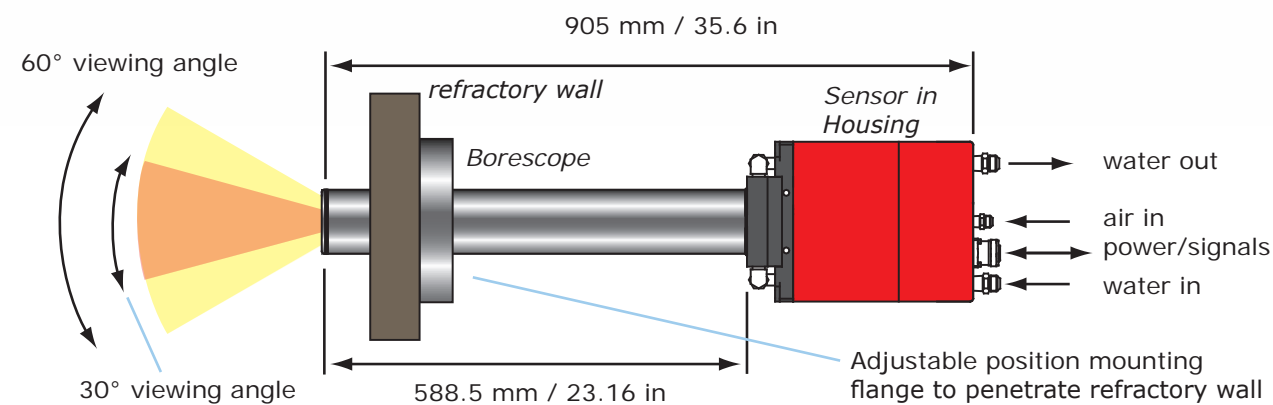

Typical installation showing the FTI-Eb mounted into a process - the sensor is shown in the protective enclosure

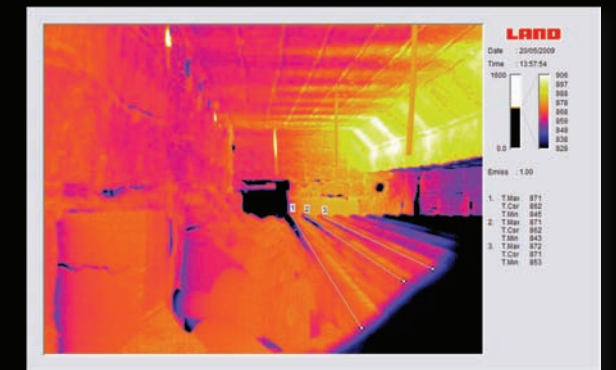

Temperature Profiles inside the furnace



Point temperature measurement inside the furnace

LAND