

JUMO cTRON 04/08/16

Compact controller
with timer and ramp function



702071



702072



702074

B 70.2070.0
Operating Manual



1	Introduction	5
1.1	Preface	5
1.2	Type designation	7
1.3	Scope of delivery	8
1.4	Accessories	8
2	Installation	9
2.1	Installation site and ambient conditions	9
2.2	Dimensions	9
2.3	Installation	13
3	Electrical connection	15
3.1	Installation notes	15
3.2	Electrical isolation	17
3.3	Connection diagram 702071	18
3.4	Connection diagram 702072, 702074	19
4	Operation	21
4.1	Display and operating elements	21
4.2	Level concept	22
4.3	User level configuration	23
4.4	Level inhibit	24
4.5	Entries and operator prompting	25
4.6	Controller	27
4.7	Display of the software version	28
5	Operator level	29
6	Parameter level	31

Content

7	Configuration level	33
7.1	Analog input	35
7.2	Controller	38
7.3	Ramp function	40
7.4	Limit comparators	42
7.5	Timer	45
7.6	Outputs	49
7.7	Binary functions	51
7.8	Display/Operation/Service counter	53
7.9	Interface	58
8	Supplement	59
8.1	Technical Data	59
8.2	Alarm and fault messages	64
8.3	Self-optimization	65

1.1 Preface

Please read this manual before commissioning the device. Keep the manual in a place accessible to all users at all times. Your comments are appreciated and may assist us in improving this manual.

All necessary settings are described in this operating manual. Manipulations not described in the manual or expressly forbidden will jeopardize your warranty rights. Please contact the nearest subsidiary or the head office, should you encounter problems.

The manual is valid from **device software version 223.01.04**

⇒ Chapter 4.7 „Display of the software version“

Warning signs



DANGER!

This symbol indicates that **Injury or death caused by electrical shock** can/may occur, if the respective protective measures are not carried out.



CAUTION!

This symbol in combination with the signal word indicates that **Damage to assets or data loss** will occur, if the respective protective measures are not carried out.

1 Introduction

Note symbols



TIP!

This symbol refers to an **Important information** about the product or its handling or additional use.



REFERENCE!

This symbol refers to **Further information** in other sections, chapters or manuals.

1.2 Type designation

Basic type

702071	Type 702071 (nominal dimension 48mm x 48mm) 1 analog input, 2 binary inputs (alternative to logic output and input 0/2...10V, resp.)
702072	Type 702072 (nominal dimension 48mm x 96mm) 1 analog input, 2 binary inputs (one binary input alternative to input 0/2...10V)
702074	Type 702074 (nominal dimension 96mm x 96mm) 1 analog input, 2 binary inputs (one binary input alternative to input 0/2...10V)

Basic type extensions

8	Standard with factory settings
9	Customer-specific programming according to specifications

Output 1 - 2 - 3 - 4

1130	Relay - Relay - Logics 0/14V
1131	Relay - Relay - Logics 0/14V - Relay
1134	Relay - Relay - Logics 0/14V - Analog output

Voltage supply

23	AC 110...240V, 48...63Hz
25	AC/DC 20...30V, 48...63Hz

Interface

00	Without
53	Interface RS485 with electrical isolation

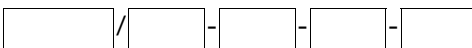

702071 / 8 - 1130 - 23 - 00

Type key

Example

1 Introduction

1.3 Scope of delivery

- Controller (including seal and fastening elements)
- Operating Manual B70.2070.0 in DIN A6 format

1.4 Accessories

Mini-CD

Mini-CD with demo setup program and PDF documents (operating manual and further documentation);

Sales No.: 70/00509007

PC interface

PC interface with TTL/RS232 converter and adapter (socket connector) for setup program; Sales No.: 70/00350260

USB interface

PC interface with USB/TTL converter, adapter (socket connector) and adapter (pins); Sales No.: 70/00456352

Setup program

PC program for device configuration, incl. JUMO-Startup;

Sales No.: 70/00506060

Required hardware:

- PC Pentium IV or compatible
- 256 MB RAM, 100 MB free fixed disk memory
- CD ROM drive
- free serial or USB interface

Required software:

Microsoft¹ Windows 2000/XP/Vista

¹ Microsoft is a registered trademark of Microsoft Corporation

2.1 Installation site and ambient conditions

The ambient conditions at the installation site must meet the requirements specified in the technical data.

⇒ Chapter 8.1 „Technical Data“

The device is not suitable for use in areas with an explosion hazard (Ex areas).

Cleaning the device front

The device front can be cleaned using warm or hot water (possibly adding slightly acidic, neutral or slightly alkaline cleaning agent). It has a limited resistance to organic solvents (e. g. methylated spirits, white spirit, etc.). Do not use abrasive or high-pressure cleaning equipment.

2.2 Dimensions

Close mounting

Minimum spacing of panel cut-outs		
Type	horizontal	vertical
without setup plug:		
702071 (48mm x 48mm)	> 8mm	> 8mm
702072 (48mm x 96mm)	> 10mm	> 10mm
702074 (96mm x 96mm)	> 10mm	> 10mm
with setup plug:		
702071 (48mm x 48mm)	> 8mm	> 65mm
702072 (48mm x 96mm)	> 10mm	> 10mm
702074 (96mm x 96mm)	> 10mm	> 10mm

2 Installation

Legend referring to the following illustrations

(1) Connection for PC interface adapter (setup plug)	(2) Panel cut-out
--	-------------------

Type 702071

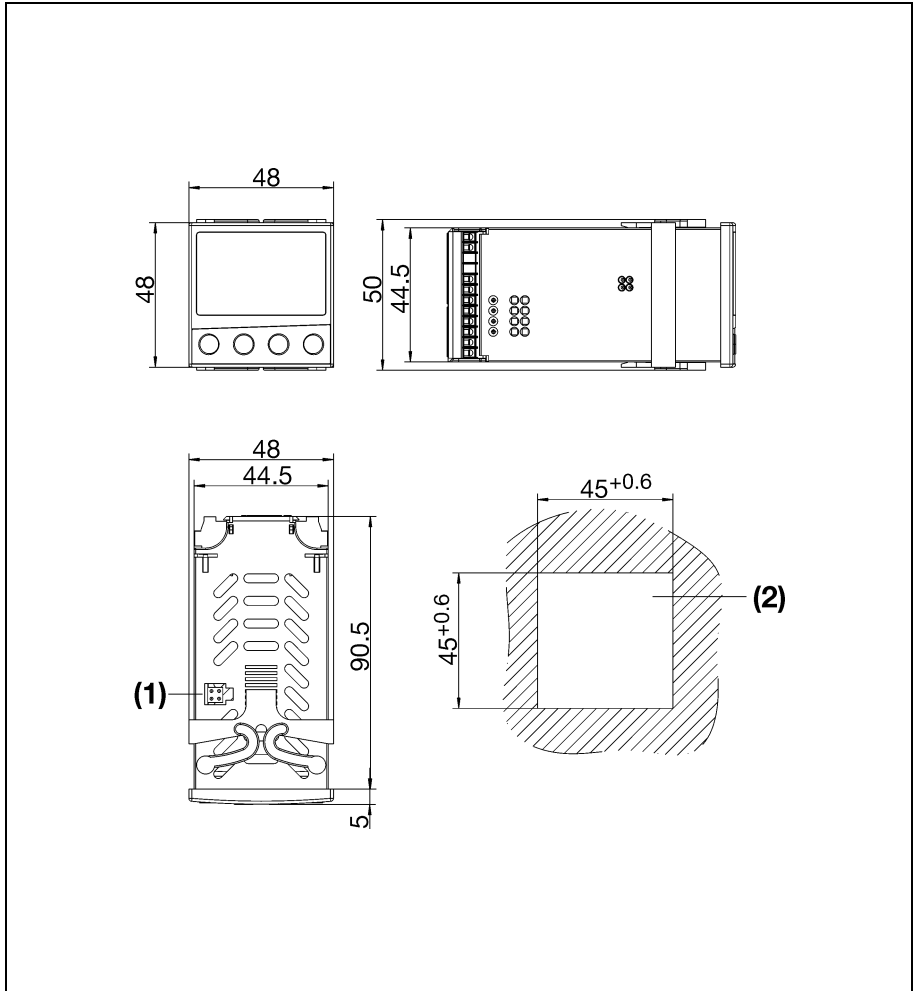

2 Installation

Type 702072

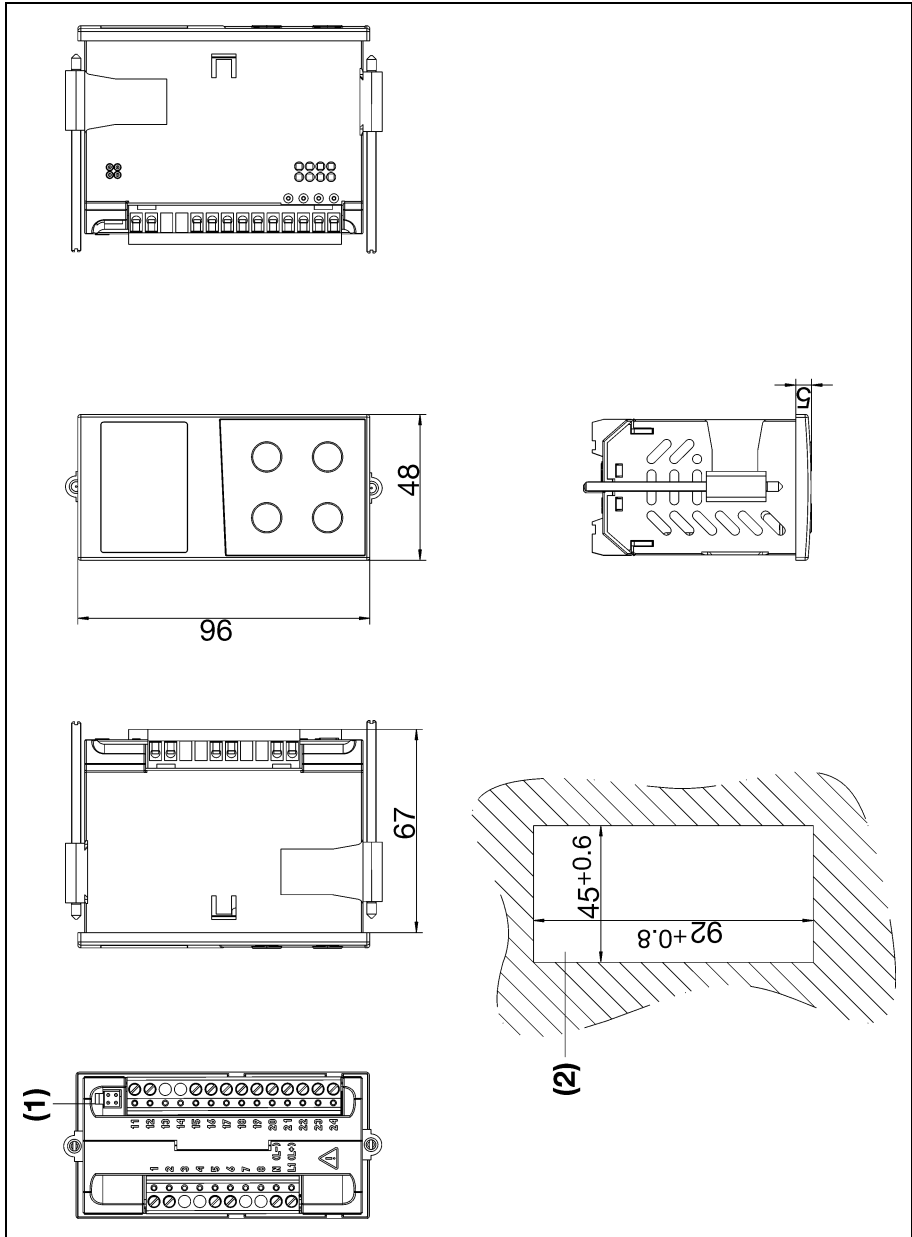

2 Installation

Type 702074

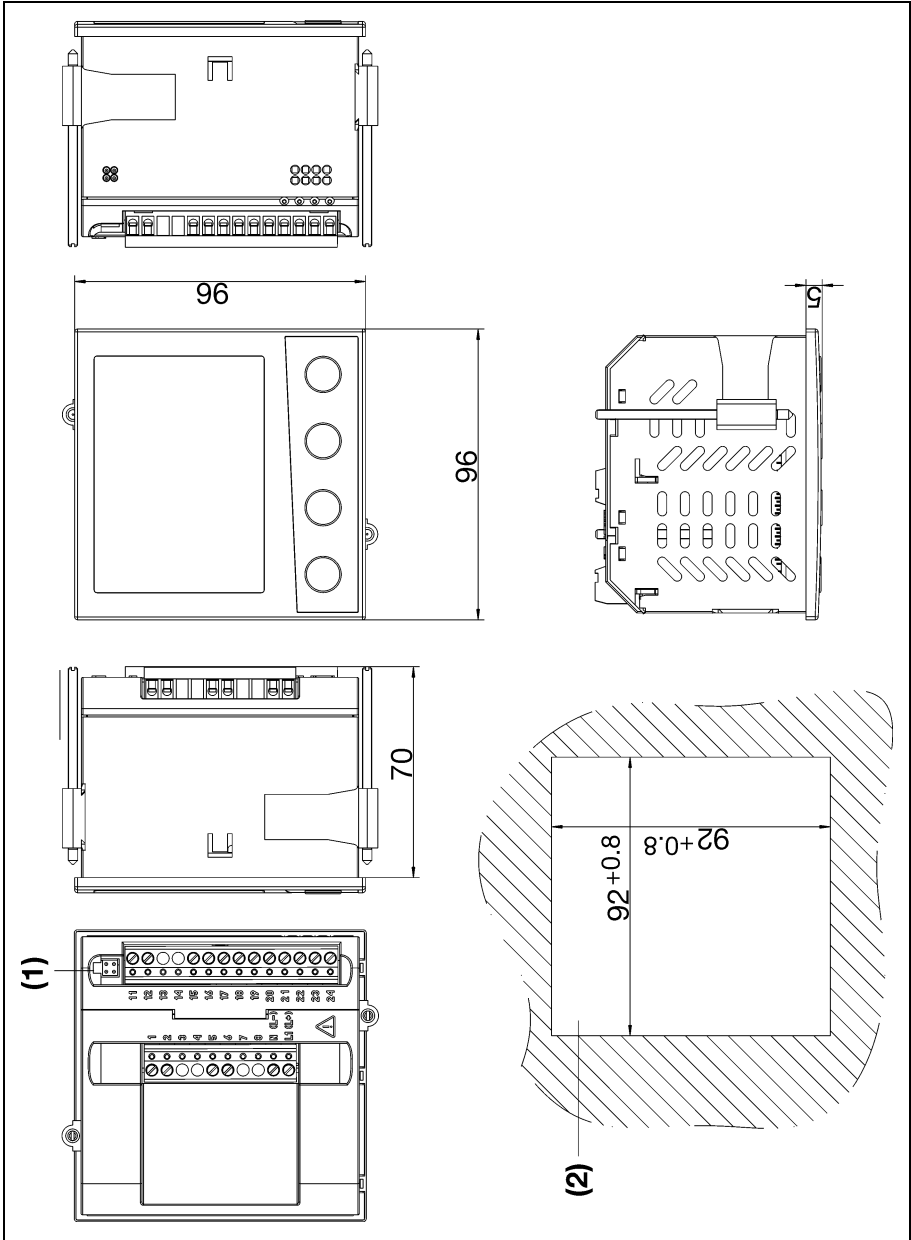

2.3 Installation

Type 702071

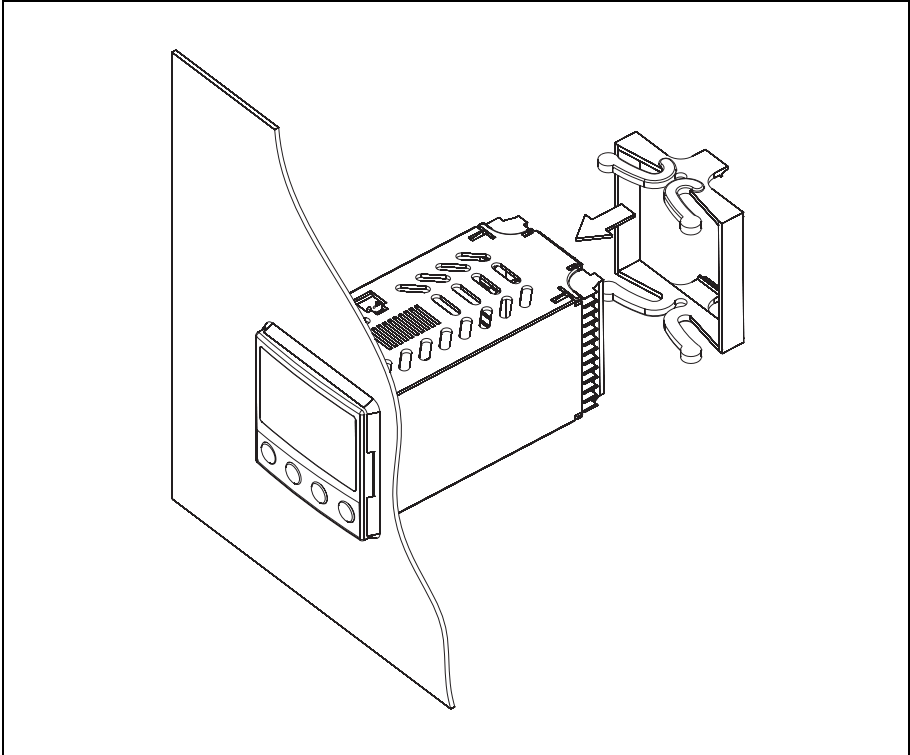

1. Insert the device from the front into the panel cut-out.
2. Push the fastening frame from the panel rear onto the device body and press the springs against the panel rear until the lugs engage in their slots and it is sufficiently fastened.

2 Installation

Type 702072 and 702074

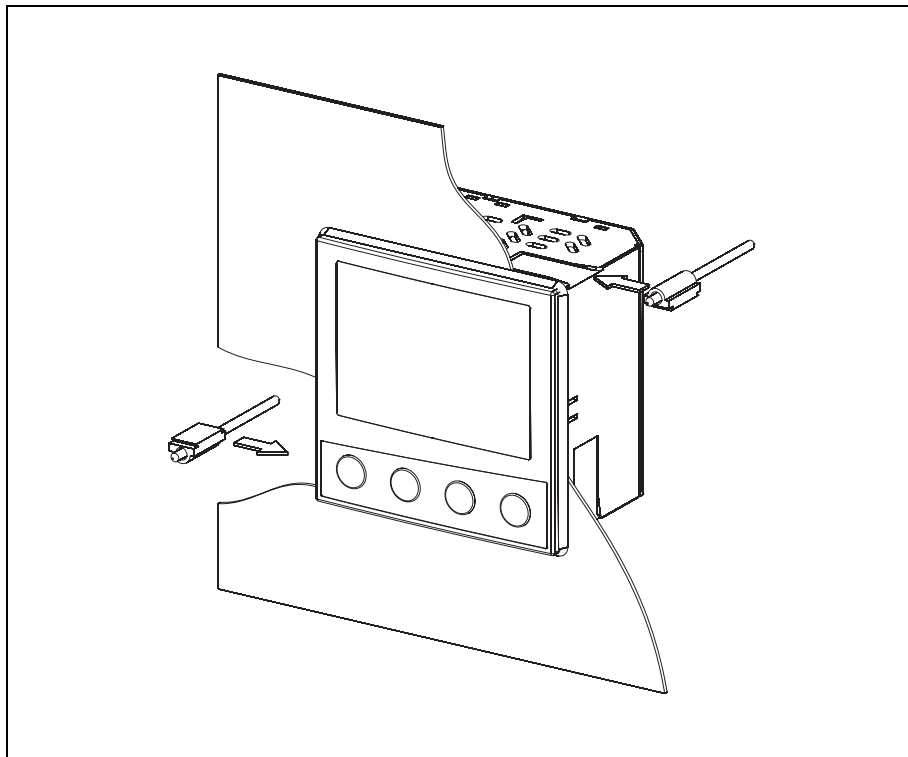

1. Insert the device from the front into the panel cut-out.
2. From the panel rear, slide the mounting brackets into the guides on the sides of the case. The flat faces of the mounting brackets must make contact with the case.
3. Place the mounting brackets against the panel rear, and tighten evenly with a screwdriver.

3 Electrical connection

3.1 Installation notes

- The choice of cable, the installation and the electrical connection of the device must conform to the requirements of VDE 0100 "Regulations on the Installation of Power Circuits with Nominal Voltages below 1000 V" or the appropriate local regulations.
- The electrical connection must only be carried out by qualified personnel.
- The instrument shall be operated by mains protected with a branch circuitry overcurrent protection device not more than 20 Amps. For servicing/repairing a Disconnecting Device shall be provided to disconnect all conductors.
- The load circuit must be fused for the maximum relay current, in order to prevent the output relay contacts becoming welded in the event of a short circuit occurring at that point.
- The electromagnetic compatibility conforms to the standards and regulations cited in the technical data.
- Run input, output and supply cables separately and not in parallel with one another.
- Sensor and interface cables should be shielded cables with twisted conductors. Do not run cables close to current-carrying components or cables. Ground the shielding on one side.
- Do not connect any additional loads to the supply terminals of the device.



DANGER!

Hazardous electrical voltage.

Injury or death caused by electric shock.

The electrical connection must only be carried out by qualified personnel.



TIP!

Identify the device version by way of the type key.

3 Electrical connection

Installation information on conductor cross sections

Lead	Type	702071	702072 702074
1 wire		$\leq 1.3\text{mm}^2$	$\leq 2.5\text{mm}^2$
fine-strand, with core-end ferrule		$\leq 1.0\text{mm}^2$	$\leq 1.5\text{mm}^2$

Plug-in terminal strips (screw terminals).

3 Electrical connection

3.2 Electrical isolation

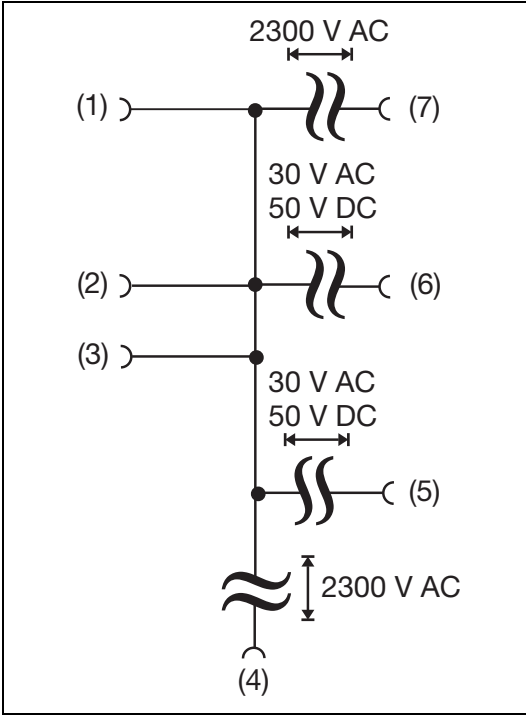

- (1) Analog input
- (2) Binary inputs/
Output K3
(Logics)
- (3) Setup interface
- (4) Voltage
supply
- (5) RS485 interface
- (6) Analog output
- (7) Outputs K1, K2 and K4
(relay)

3 Electrical connection

3.3 Connection diagram 702071

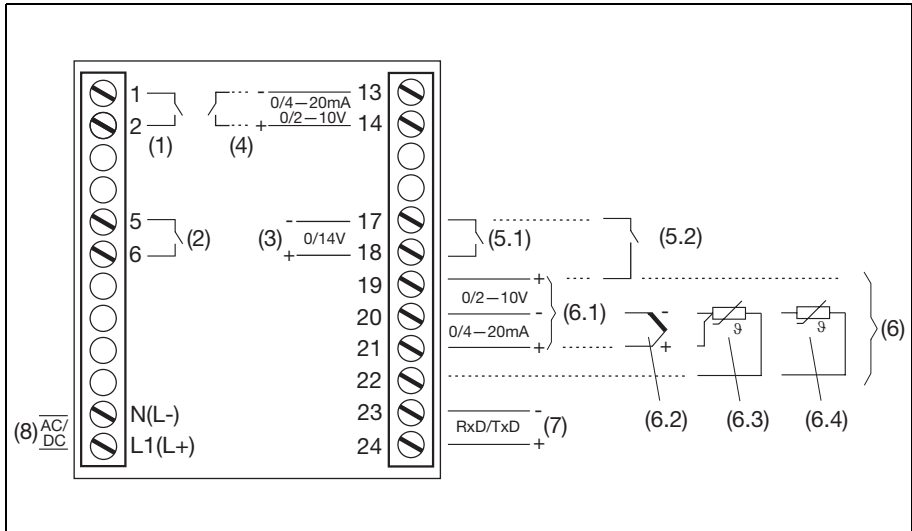

- | | |
|---|---|
| (1) Output 1 (K1):
Relay 230V AC/3A | (2) Output 2 (K2):
Relay 230V AC/3A |
| (3) Output 3 (K3): Logic 0/14V
(alternative to binary input 1,
configurable) | (4) Output 4 (K4) (option):
Analog output or
Relay 230V AC/3A |
| (5.1) Binary input 1
(for potential-free contact);
(alternative to output 3, configu-
rable) | (5.2) Binary input 2 (for potential-free
contact); (alternative to input
0/2—10V, configurable with
setup program) |
| (6) Analog input | |
| (6.1) Standard signals
(input 0/2—10V alternative to
binary input 2) | (6.2) Thermocouple |
| (6.3) RTD temperature probe
(3 wire) | (6.4) RTD temperature probe
(2 wire) |
| (7) RS485 interface
(Option) | (8) Voltage supply
110—240V AC
(Option: 20—30V AC/DC) |

3 Electrical connection

3.4 Connection diagram 702072, 702074

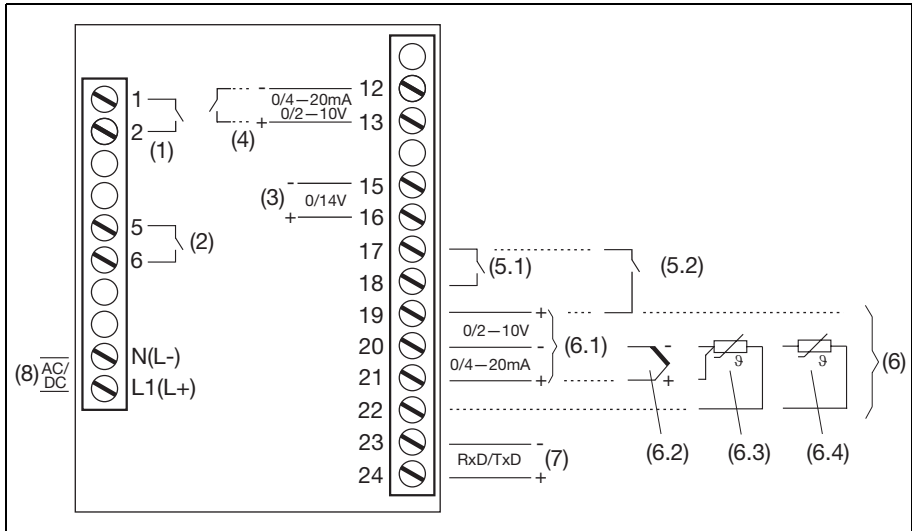





- | | |
|--|---|
| (1) Output 1 (K1):
Relay 230V AC/3A | (2) Output 2 (K2):
Relay 230V AC/3A |
| (3) Output 3 (K3): Logic 0/14V | (4) Output 4 (K4) (option):
Analog output or
Relay 230V AC/3A |
| (5.1) Binary input 1
(for potential-free contact) | (5.2) Binary input 2 (for potential-free
contact); (alternative to input
0/2—10V, configurable with
setup program) |
| (6) Analog input | |
| (6.1) Standard signals
(input 0/2—10V alternative to
binary input 2) | (6.2) Thermocouple |
| (6.3) RTD temperature probe
(3 wire) | (6.4) RTD temperature probe
(2 wire) |
| (7) RS485 interface
(Option) | (8) Voltage supply
110—240V AC
(Option: 20—30V AC/DC) |

3 Electrical connection

4.1 Display and operating elements



- (1) **Red 7-segment display** (factory-setting: Process value);
4-digit, configurable decimal place (automatic adjustment on display overflow)
- (2) **Green 7-segment display** (factory-setting: Set point value);
4-digit, configurable decimal place, serves also for operator guide (display of parameter and level symbols)
- (3) **Signals, yellow LED**
Switching states of the binary outputs 1 ... 4
(display lit = ON)
- (4) **Keys**
 -  Programming, one level deeper
 -  leave level / function key
⇒ Chapter 7.8 „Display/Operation/Service counter“
 -  Value reduction / previous parameter
 -  Value increase / next parameter
- (5) **Signals, green LED**
 - Manual mode active
 - Ramp function active
 - Timer active

4 Operation

4.2 Level concept

The parameters for device setting are organised at different levels.

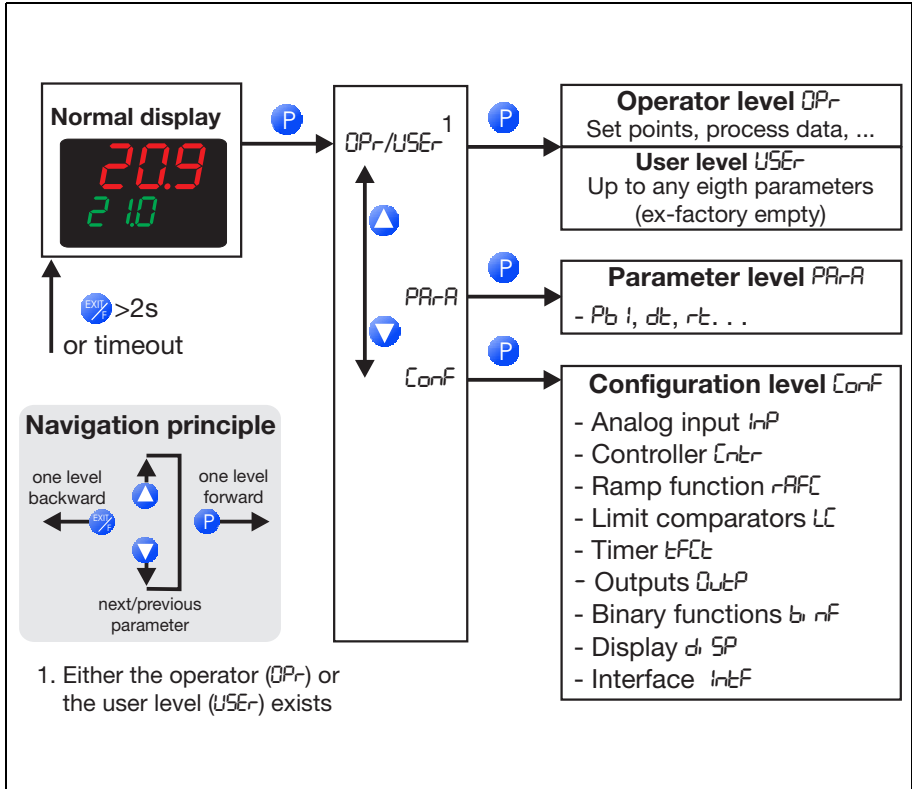

- ⇒ Chapter 5 „Operator level“
- ⇒ Chapter 6 „Parameter level“
- ⇒ Chapter 7 „Configuration level“



TIP!

If no key is pressed for 180s the device changes back to normal display (factory-setting). The setting can be changed in the setup program (Display/Operation/Service counter -> Operation -> Time-out).

4.3 User level configuration

A maximum of eight parameters to be available in the user level can be selected in the setup program.

The user can assign a name to each parameter which appears on the device. Four characters that can be presented by a 7-segment display are permissible. If no name is assigned, the name used in factory appears on the device.

The following figure shows an example (ex-factory all parameters are switched off).

The screenshot shows a configuration window titled "User level" with tabs for "display", "Operation", "User level", and "Service counter". The "User level" tab is active. The window contains a table with 8 rows, each representing a parameter. The columns are "Parameter:", "Value:", and "Name:". The values are "Service time", "Service interval", and "Switched off" for parameters 1 through 8. The names are "DC" and "oCAL" for parameters 1 and 2, and empty for parameters 3 through 8. At the bottom right, there are "OK" and "Cancel" buttons.

Parameter:	Value :	Name :
1	Service time	DC
2	Service interval	oCAL
3	Switched off	
4	Switched off	
5	Switched off	
6	Switched off	
7	Switched off	
8	Switched off	

4 Operation









TIP!

The parameters selected here are displayed in the user level (*USER*). Then the operator level (*OPR*) is no longer visible. Select parameters from the operator level here, if required.

4.4 Level inhibit

Access to the individual levels can be inhibited.

Code	Operator, User level	Parameter level	Configuration level
0	free	free	free
1	free	free	inhibited
2	free	inhibited	inhibited
3	inhibited	inhibited	inhibited

1. For code entry use  and  (simultaneously for > 5s)
2. Change code by pressing  (display blinks!)
3. Enter code using  and 
(Ex-factory: all levels enabled)
4. Return to the normal display using  or automatic return after 180s

The parameter and configuration level can also be inhibited via the binary function.

⇒ Chapter 7.7 „Binary functions“

4.5 Entries and operator prompting

Entering values

When entries are made within the levels, the parameter symbol appears in the lower display.

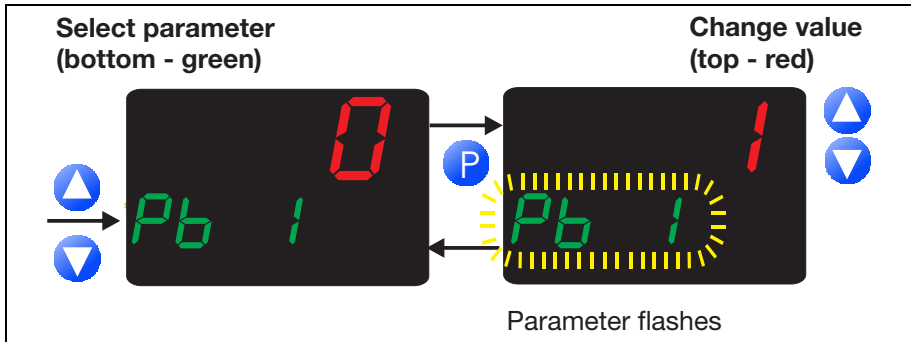

1. Select parameter by pressing or
2. Change to the entry mode using (lower display blinks)
3. Change a value using and . The value alters dynamically for as long as the key is kept pressed.
4. Take over the entry with or automatic return after 2s

or cancel the entry with . The value will not be applied.



TIP!

If the function key is pressed for > 2s, the device changes back to normal display.

4 Operation

Time entry

A decimal place is mapped in the centre and on the right to display times.

The time unit can be configured.

⇒ Chapter 7.5 „Timer“

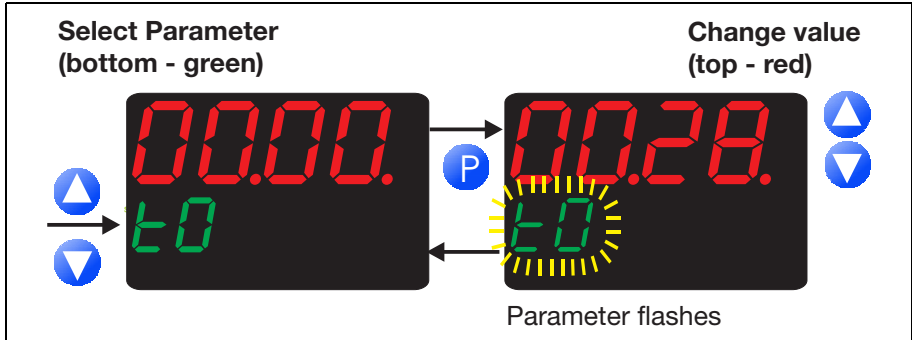

1. Select parameter by pressing or
 2. Change to the entry mode using (lower display blinks)
 3. Change a value using and
The value alters dynamically for as long as the key is kept pressed.
 4. Take over the entry with or automatic return after 2s
- or cancel the entry with
The value will not be applied.

4.6 Controller

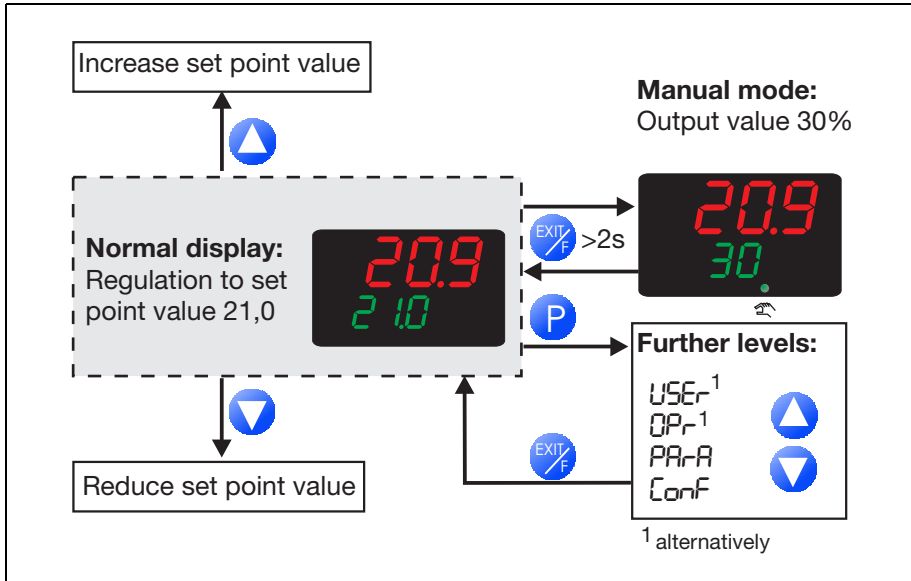



Normal display

In normal display, the controller regulates to the entered set point value.

Changing the set point value

From the normal display:



1. Change the set point value using  and  (the value will be automatically applied)

The longer the key is kept pressed, the faster the set point value changes.

4 Operation

Changing to the manual mode

In the manual mode, the controller output value can be changed manually.

1. Change to the manual mode using function key  (> 2s)
(ex-factory setting)
 - ➔ The output value is displayed in percent in the lower display.
The "Manual mode active" LED is also lit.
2. Change the output value using  and 
With a modulating controller, the actuator is opened or closed using the keys.

The various levels can be accessed in the manual mode.

The setup program can be used to configure the default output value on a changeover. The manual mode can also be inhibited.

⇒ Chapter 7.2 „Controller“

The controller automatically changes to manual mode in the event of overrange/underrange and probe break.

Manual mode exit

1. Exit the manual mode using function key  (> 2s)

Operation via binary functions

Further operating possibilities for the fixed value controller can be realised via binary functions.

⇒ Chapter 7.7 „Binary functions“

4.7 Display of the software version

Simultaneously press the  and  keys to display the software version.

Four-digit display; example:

"01.01" in case of software version xxx.01.01

5 Operator level

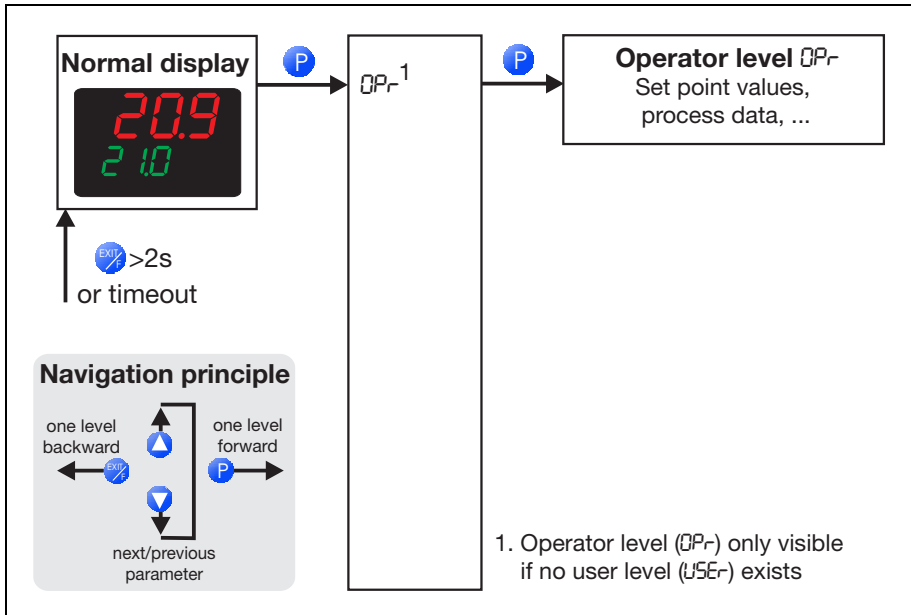

Levels can be inhibited.

⇒ Chapter 4.4 „Level inhibit“

5 Operator level

Parameters

Depending on the configuration, the following values are displayed:

Symbol	Meaning
SP_1	Set point value 1 (can be edited)
SP_2	Set point value 2 (can be edited), only when switching over to set point value 2 ⇒ Chapter 7.7 „Binary functions“
SP_r	Ramp set point value (only if configured) ⇒ Chapter 7.3 „Ramp function“
INP_1	Measured value of analog input 1
y	Output value
t_1	Timer time (only if configured and timer is not running) ⇒ Chapter 7.5 „Timer“
t_L	Timer running time (only if timer runs) ⇒ Chapter 7.5 „Timer“
t_r	Residual timer running time (only if timer runs) ⇒ Chapter 7.5 „Timer“
OC	Service counter display (only if service counter runs or as long as a reached limit value was not reset) ⇒ Chapter 7.8 „Display/Operation/Service counter“

6 Parameter level

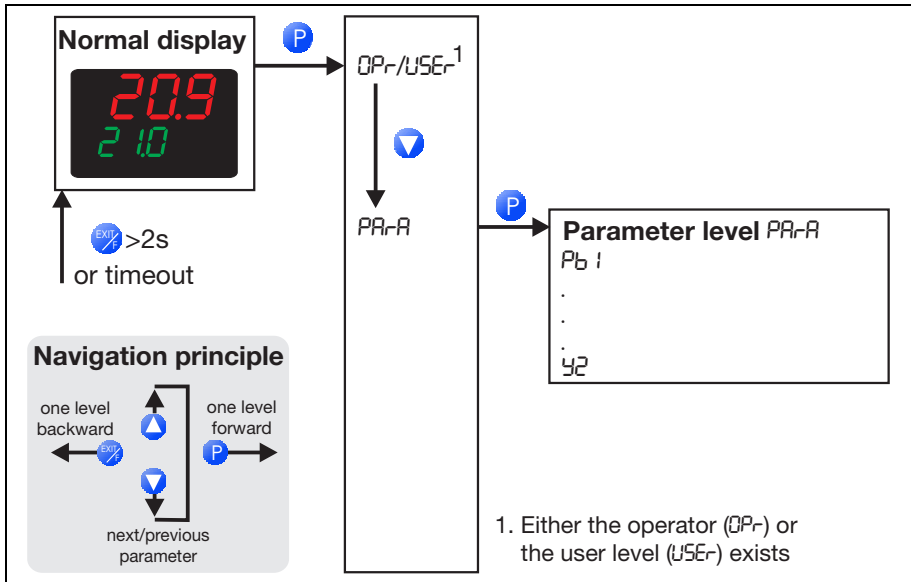

Levels can be inhibited.

⇒ Chapter 4.4 „Level inhibit“

Parameters	Symbol	Value range	Description
Proportional band	$Pb\ 1$	0...9999	Dimension of the proportional band The larger the proportional band the lower the controller amplification. At $Pb_{1,2}=0$, the controller structure is ineffective (limit comparator behavior). For the continuous controller $Pb_{1,2}$ must be >0 .
	$Pb\ 2$	0...9999	
Derivative time	dt	0...80... 9999s	Influences the differential component of the controller output signal The larger the derivative time the higher the effectiveness of the D component.
Reset time	rt	0...350... 9999s	Influences the integral component of the controller output signal The larger the reset time the lower the effectiveness of the I component.
1) For 3-state controllers only (controller output 2)			

6 Parameter level

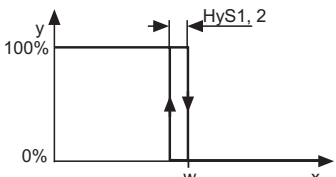
Cycle time of output	[y1]	0.0... 20.0 ... 999.9s	For a switching output, the cycle time should be selected so that, on one hand, no inadmissible process value fluctuations are generated caused by the cycled energy supply and, on the other hand, no overload of the acutators occurs.
	[y2] 1)	0.0... 20.0 ... 999.9s	
Dead band	db	0.0 ... 999.9	Spacing between the two control contacts of the 3-state controller and the modulating controller
Hysteresis	HYS1	0.0... 1.0 ... 999.9	Hysteresis for switching controller with Pb1,2 = 0. 
	HYS2 1)	0.0... 1.0 ... 999.9	
Valve run time	tt	5... 60 ... 3000s	Used run time range of the control valve (actuator) of the modulating controller
Operating value	y0	-100... 0 ... +100%	Output value for P and PD controllers (for x=w is y=Y0)
Output value limits	y1	0... 100 %	Maximum output value limit
	y2	-100 ... +100%	Minimum output value limit (Only effective when Pb>0!)
1) For 3-state controllers only (controller output 2)			

Factory settings are shown **bold**.

Parameter display independent of the controller type:

⇒ Chapter 7.2 „Controller“

Decimal places for some parameters depend on the device setting:

⇒ Chapter 7.8 „Display/Operation/Service counter“

7 Configuration level

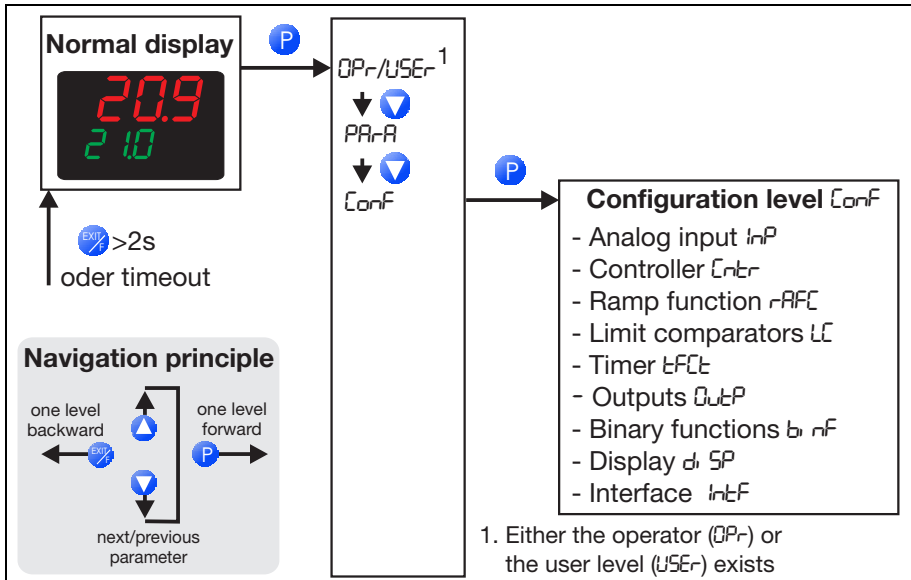

Levels can be inhibited.

⇒ Chapter 4.4 „Level inhibit“



TIP!

Parameters are not displayed unless the equipment level permits the function assigned to the parameter. This means, for example, that interface parameters can only be configured, if the device is equipped with an interface.



TIP!

Some parameters can only be programmed through the setup program. In the following tables, these are marked in the "Parameters" column with "(Setup)".



TIP!

Factory settings are displayed **bold** in the following tables in the "Value/Selection" and "Description" columns.

7 Configuration level



TIP!

For activation of binary input 2 the setup program is required (Hardware assistant).

Analog selector

Some parameters in the Configuration level allow users to select from a series of analog values. The list below shows all available signals.

Value	Description
0	deactivated
1	Analog input
2	Process value
3	current set point value
4	Ramp limit value
5	Ramp set point value
6	(reserved)
7	(reserved)
8	Set point value 1
9	Set point value 2
10	Controller output value (-100%...+100%)
11	Controller output 1 (0...+100%; e. g. „Heating“)
12	Controller output 2 (0...-100%; e. g. „Cooling“)
13	Timer run time (time unit of the timer)
14	Residual timer run time (time unit of the timer)
15	(reserved)
16	(reserved)
17	(reserved)

7 Configuration level

7.1 Analog input

One analog input is available.

`CONF -> InP ->`

Parameters	Value/ Selection	Description
Sensor type SEn5	0	RTD temperature probe Pt100 3 wire
	1	RTD temperature probe Pt1000 3 wire
	2	RTD temperature probe Pt100 2 wire
	3	RTD temperature probe Pt1000 2 wire
	4	KTY 2 wire
	5-9	(reserved)
	10	Cu-CuNi T
	11	Fe-CuNi J
	12	Cu-CuNi U
	13	Fe-CuNi L
	14	NiCr-Ni K
	15	Pt10Rh-Pt S
	16	Pt13Rh-Pt R
	17	Pt30Rh-Pt6Rh B
	18	NiCrSi-NiSi N
	19	NiCr-CuNi E
	20	W5Re_W26Re C
	21	W3Re_W25Re D
	22	W3Re_W26Re
	23	0...20mA
	24	4...20mA
	25	0...10V
	26	2...10V

7 Configuration level

Parameters	Value/ Selection	Description									
Measured value offset <i>OFFS</i>	-1999... 0... +9999	The measured value correction (offset) is used to correct a measured value by a certain amount upward or downward. Examples: <table style="margin-left: 20px;"> <tr> <td>Measured value</td> <td>Offset</td> <td>Displayed value</td> </tr> <tr> <td>294.7</td> <td>+0.3</td> <td>295.0</td> </tr> <tr> <td>295.3</td> <td>- 0.3</td> <td>295.0</td> </tr> </table>	Measured value	Offset	Displayed value	294.7	+0.3	295.0	295.3	- 0.3	295.0
Measured value	Offset	Displayed value									
294.7	+0.3	295.0									
295.3	- 0.3	295.0									
Scale low level <i>SCL</i>	-1999... 0... +9999	On transducers with standard signal, a display value is assigned to the physical signal (scaling). Example: 0 ... 20mA = 0 ... 1500°C.									
Scale high level <i>SCH</i>	-1999... 100... +9999	The range of the physical signal can be 20% wider or narrower without generating an overrange/underrange signal.									
Digital filter <i>dF</i>	0.0... 0.6... 100.0	To adapt the digital input filter (time in seconds; 0s = filter off). 63% of the alterations are acquired after 2x filter time constant (2nd order filter) at a step change. When the filter time constant is large: -high damping of interference signals -slow reaction of the process value display to process value changes -low limit frequency (low-pass filter)									



CAUTION!

Measured value offset: The controller uses the corrected value for calculation (= displayed value). This value does not comply with the value measured at the measuring point. Incorrect use can cause inadmissible control values. Only carry out a measured value offset within the admissible range.

7 Configuration level

Parameters	Value/ Selection	Description
Temperature unit <i>Unit</i>	1 2	deg. Celsius deg. Fahrenheit Unit for temperature values
Correction value KTY at 25°C (Setup)	0... 2000 ... 4000	Resistance in ohms at 25°C/77°F for „KTY 2-wire“ probe type Setting in the setup program (-> Analog input -> Analog input 1)

7 Configuration level

7.2 Controller

Controller type and controller input values, set point limit values, functions for manual mode and the presettings of self-optimization are set here.

CONF -> CNTR ->

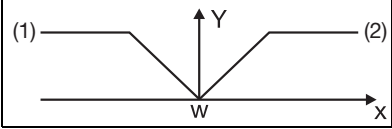
Parameters	Value/ Selection	Description
Controller type CTYP	1 2 3 4	2-state controller 3-state controller Modulating controller Continuous controller
Control direction CACT	0 1	Direct Inverse  <p>(1) = Inverse: Output value Y of the controller is > 0, if process value x is smaller than set point value w (e.g. heating).</p> <p>(2) = Direct: Output value Y of the controller is > 0, if process value x is higher than set point value w (e.g. cooling).</p>
Output value, manual mode HRnd	-100... +101	Defines the output value after switching to manual mode. 101 = last output value For modulating controllers: 0 = Actuator closes 100 = Actuator opens 101 = Actuator stops Setting in the setup program (-> Controller -> Output value, manual mode)

7 Configuration level

Parameters	Value/ Selection	Description
Output value at Out of Range <i>rOut</i>	-100... 0... +101	Output value in the event of overrange or underrange. 101 = last output value For modulating controllers: 0 = Actuator closes 100 = Actuator opens 101 = Actuator stops Setting in the setup program (-> Controller -> Output value at Out of Range)
Set point limit low <i>SPL</i>	-1999... +9999	The set point limitation prevents the entry of values outside the default range. The set point limit values are not effective when entering set point default values via the interface. The correction value is limited for external set point values with offset.
Set point limit high <i>SPH</i>	-1999... +9999	
Process value for controller <i>CP</i>	(analog selector) Analog input	Determines the source of the controller process value. ⇨ Analog selector, page 34
Manual mode (Setup)	free inhibited	If the manual mode is inhibited, it is not possible to change to the manual mode using the keys or the binary input. Setting in the setup program (-> Controller -> Manual mode)
Self- optimization (Setup)	free inhibited	If self-optimization is inhibited, it cannot be started using keys or the binary function. ⇨ Chapter 8.3 „Self-optimization“ Setting in the setup program (-> Controller -> Self-optimization) Self-optimization is also inhibited, if the parameter level is inhibited. ⇨ Chapter 7.7 „Binary functions“ ⇨ Chapter 7.8 „Display/Operation/Service counter“

7 Configuration level

7.3 Ramp function

The device can be operated as a fixed value controller with and without ramp function.

When the ramp function is active, a new temperature set point value is controlled along a ramp and no longer as a step. It is possible to realize an ascending or descending ramp function. The ramp limit value is defined by the set point default value.

[ONF -> rAF[->

Parameters	Value/ Selection	Description
Function Fnc[0 deactivated 1 Ramp Kelvin/Minute 2 Ramp Kelvin/Hour 3 Ramp Kelvin/Day	<p>The ramp limit value can be changed using the ▲ or ▼ keys.</p> <p>(1) = Set point value (2) = Process value t1: Power ON/Ramp start (w1 active) t2-t3: Mains failure/Manual mode/Probe break t4-t5: Ramp stop t6: Set point value changeover to w2</p> <p>The ramp function can be stopped, cancelled and restarted using binary functions. ⇒ Chapter 7.7 „Binary functions“</p>

7 Configuration level

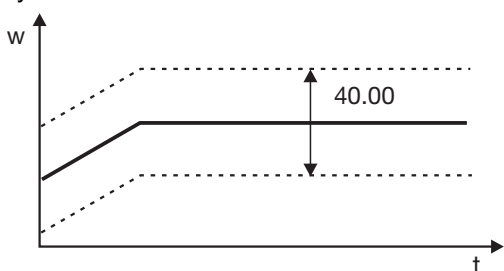
Parameters	Value/ Selection	Description
Ramp rate $rASL$	0.0... 999.9	Value of ramp rate (for functions 1 to 3 only)
Tolerance band $toLP$	0...9999	<p>Range of the tolerance band (in Kelvin) around the set point value 0 = Tolerance band inactive (for functions 1 to 3 only)</p> <p>For the ramp function, it is possible to enter a tolerance band around the set point value curve to monitor the process value. A tolerance band signal to be used internally or transmitted via an output is triggered when the upper or lower limit is exceeded.</p> <p>In the following example, the tolerance band ($toLP$) is 40K. Thus a tolerance band signal is triggered when the process value exceeds the upper or lower set point value by 20K.</p>  <p>Further information about the use of the tolerance band signal: ⇒ Chapter 7.6 „Outputs“ ⇒ Chapter 7.7 „Binary functions“</p>



TIP!

The ramp function is cancelled in the event of a probe break or in manual mode. The outputs react in the same manner as for an overrange/underange (configurable).

7 Configuration level

7.4 Limit comparators

Limit comparators (threshold monitors, limit contacts) can be used to monitor the limit comparator process value against a fixed alarm value or an alarm value depending on the limit comparator set point value. When an alarm value is exceeded, a signal can be output or an internal controller function initiated.

2 limit comparators are available (LC1, LC2).

Limit comparators can have different switching functions (lk1 to lk8). The switching differential HySt can be set and is, in all cases, symmetrical in relation to the alarm value (AL).

Alarm value AL relative to set point value w

The limit comparator functions lk1 to lk6 monitor the process value x for an alarm value AL to be set, the absolute value depending on set point value w .

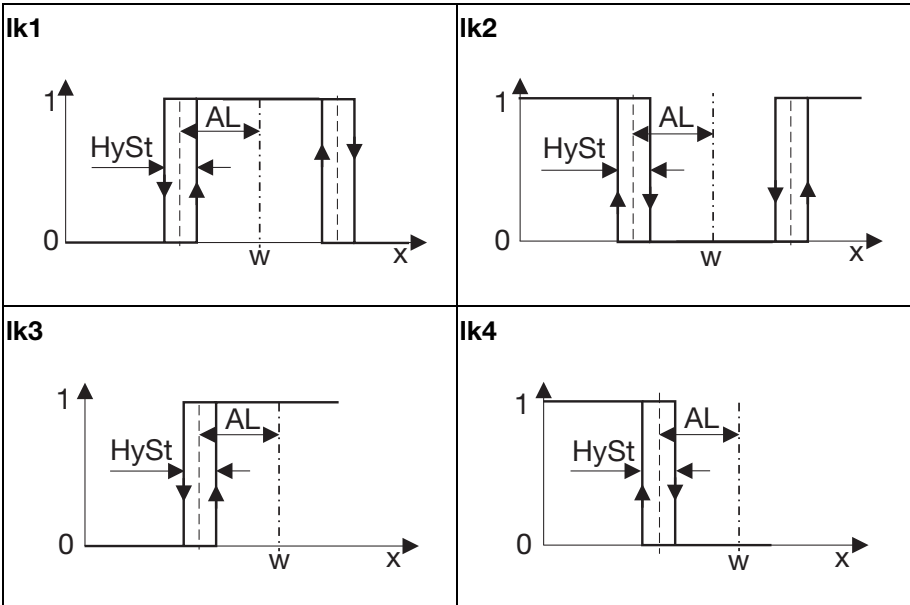

7 Configuration level

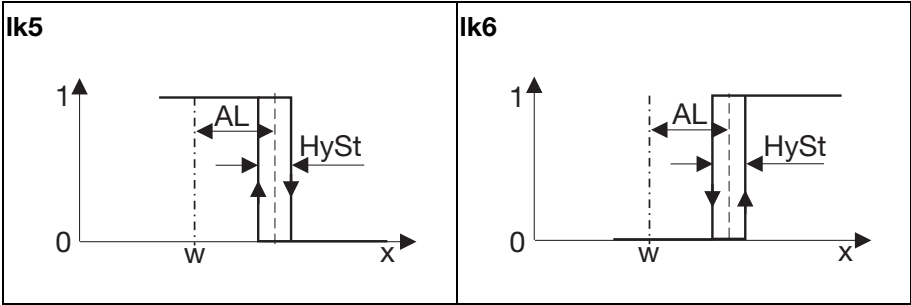

Fixed alarm value AL

The limit comparator functions Ik7 and Ik8 monitor the process value x for a fixed alarm value AL to be set.

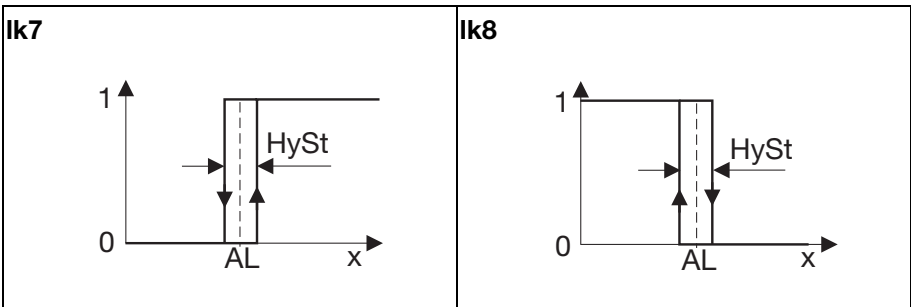

7 Configuration level

CONF -> LC -> LC1, LC2 ->

Parameters	Value/ Selection	Description
Function <i>FnCt</i>	0 1 2 3 4 5 6 7 8	no function lk1 lk2 lk3 lk4 lk5 lk6 lk7 lk8
Alarm value <i>AL</i>	-1999... 0 ... +9999	Alarm value (limit value) to be monitored (see limit comparator functions lk1...lk8: alarm value AL) Alarm value range for lk1 and lk2: 0...9999
Hysteresis <i>HYSt</i>	0... 1 ... 9999	Hysteresis in respect to the alarm value (see limit comparator functions lk1...lk8: hysteresis HySt)
Response by Out of Range <i>ACrA</i>	0 1	Switching state in the event of overrange or underrange („Out of Range“) off on
Limit comparator process value <i>LCPr</i>	(analog selector) Process value	Input variable for limit comparator ⇒ Analog selector, page 34 (see limit comparator functions lk1...lk8: process value x)
Limit comparator set point value <i>LCSP</i>	(analog selector) Current set point value	Set point value for limit comparator ⇒ Analog selector, page 34 (see limit comparator functions lk1...lk6: set point value w)

7.5 Timer

Timer signal

A timer signal (tF1) is provided which can be transmitted via binary outputs or used for internal links, e. g. to switch off the **controller** (output value 0%) or **to toggle the set point values**.

⇒ Chapter 7.6 „Outputs“ and Chapter 7.7 „Binary functions“

The timer signal is active either when the timer runs or during the timer follow-up time (see below). The signal can be inverted via the „SiGn“ parameter.

Timer time

The timer runs for the set time t1.

Timer time, current timer running time and residual timer time can be displayed in the operator or user level (the timer time can also be changed here).

Starting the timer

The start behavior can be set and triggered via power ON, function key or binary signal. Subsequently, the timer time t1 is counted to zero either immediately or after the process value has reached a programmable tolerance limit. The timer can be stopped (waiting time) or cancelled.

How can I see that the timer is running?

The green timer LED above the clock symbol flashes while the timer time counts down, and, if a timer value is displayed on the green display, its middle decimal place (xx.xx) flashes.

Timer follow-up time

When the timer follow-up time t2 is activated, it starts after the timer has elapsed. The timer follow-up time can be used, e. g. to control a horn.

7 Configuration level

Timer in connection with the ramp function

In general, set point values can also be moved to with the ramp function. For timer functions started via the tolerance limit, only the set point value (ramp limit value) is monitored.

Timer signals

The additional signals "Timer running", "Timer waiting" and "Timer completed" can be used for binary outputs.

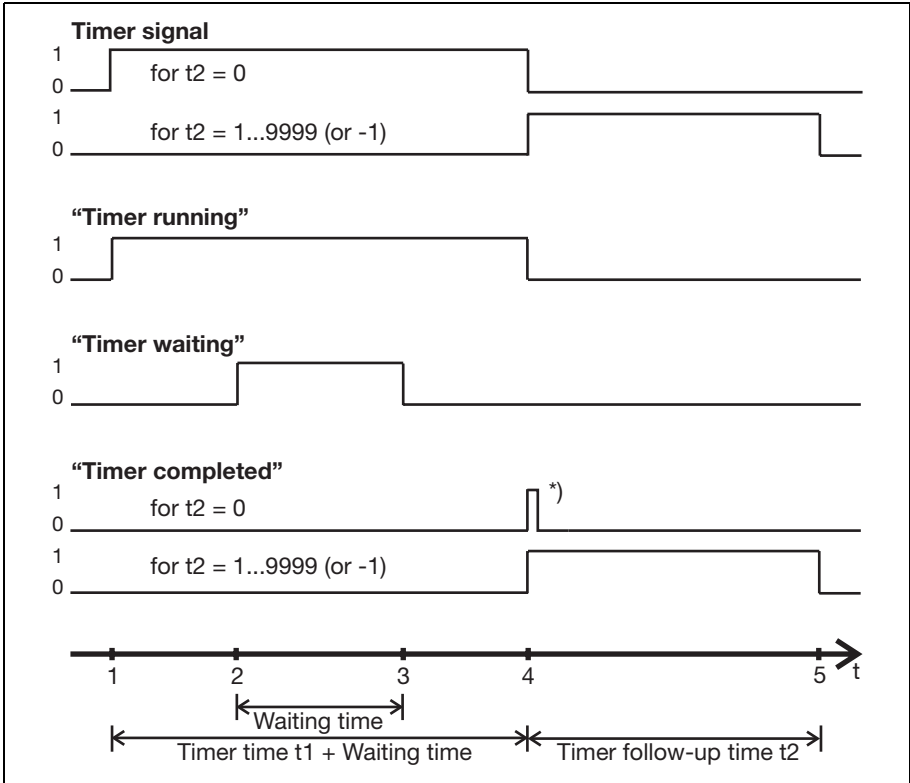

- | | | | |
|---|---------------------|----|-------------------------------|
| 1 | Timer started | 4 | Timer elapsed |
| 2 | Timer stopped | 5 | Timer follow-up time elapsed |
| 3 | Timer run continued | *) | Short pulse ("Wiper contact") |

7 Configuration level

Conf -> tFct ->

Parameters	Value/ Selection	Description
Function <i>Fnc</i>	0 1 2	no function Timer Timer for time-delayed control
Start condition <i>Start</i>	0 1 2	Manual start by using the function key or the binary signal (no restart or continuation after power supply interruption) 1 Manual start with automatic start or restart after power ON 2 Manual start and continuation after power supply interruption (residual running time is saved every minute)
Time unit <i>Unit</i>	0 1 2	mm.ss hh.mm hhh.h
Timer signal <i>S, Sn</i>	0 1	inverted not inverted
Set time t1 <i>t1</i> (Timer time)	00.00. .. 99.99.	The started timer runs for this time in the specified time unit.
Set time t2 <i>t2</i> (Timer follow-up time)	-1... 0... +9999	This time (in seconds) can be used to transmit a time limited or acknowledgeable signal after the timer time has elapsed. 0 = switched off 1...9999 = active for the set time -1 = active until acknowledged Acknowledgement: For t2 = -1 the timer follow-up time is infinite. Cancel the signal using a function key or the binary signal.

7 Configuration level

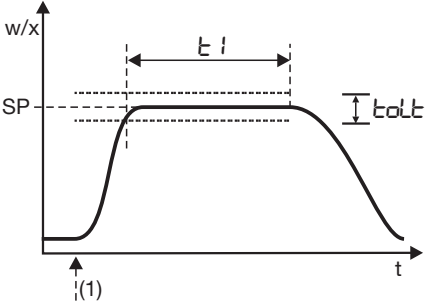
Parameters	Value/ Selection	Description
Tolerance band t_{oLl}	0...9999	<p>The set timer time only elapses when the process value has reached the tolerance band.</p> <p>0 = Start without tolerance band</p> <p>The tolerance band (in Kelvin) is symmetrical in relation to the SP set point value.</p>  <p>(1) = Start via function key, binary input or when power ON</p>

7 Configuration level

7.6 Outputs

The configuration of the device outputs is subdivided in binary outputs (OutL) and analog outputs (OutA). Binary outputs are relays and logic outputs. The switching states of the binary outputs 1 to 4 are shown in the display (K1 to K4).

Binary outputs

Output 1 (Out1) = Relay

Output 2 (Out2) = Relay

Output 3 (Out3) = Logic output

Output 4 (Out4) = Relay (option)

CONF -> OutP -> OutL ->

Parameters	Value/ Selection	Description
Binary outputs	0	no function
Out1	1	Controller output 1 (factory-set to Out1) (e.g. „Heating“, with inverse control direction)
Out2	2	Controller output 2 (e.g. „Cooling“, see above)
Out3	3	Binary input 1
Out4	4	Binary input 2
	5	Limit comparator 1
	6	Limit comparator 2
	7	Timer signal
	8	Timer runs
	9	Timer completed
	10	Timer waiting
	11	(reserved)
	12	(reserved)
	13	Tolerance band signal, ramp
	14	Ramp end signal
	15	Service alarm
	16	(reserved)
	17	Actuate the F key
	18	Manual mode

7 Configuration level

Analog output

The device can optionally be equipped with an analog output.

Conf -> OutP-> OutA ->

Parameters	Value/ Selection	Description
Function <i>Func</i>	(Analog selector) Controller output 1	Function of the output ⇒ Analog selector, page 34
Type of signal <i>S, En</i>	0 1 2 3	0...10V 2...10V 0...20mA 4...20mA Physical output signal
Value at Out of Range <i>rOut</i>	0...101	Signal (in percent) at overrange or underrange 101=last output signal
Zero point <i>OPnt</i>	-1999... 0... +9999	A value range of the output variable is assigned to a physical output signal. The ex-factory setting corresponds to an output value of 0... 100% for controller outputs.
End value <i>End</i>	-1999... 100... +9999	No changes of the ex-factory setting are required for continuous controllers. For a 3-state controller , enter the following settings for cooling: Zero point = 0 / End value = -100 Example (function as a transducer): The analog output (0...20mA) is to be used to put out the process value (value range: 150...500°C), this means: 150...500°C = 0...20mA Zero point: 150 / End value: 500

7 Configuration level

7.7 Binary functions

In terms of this manual a function initiated by a binary signal is called "binary function".

Several binary functions can be realized by using the signals of binary inputs, limit comparators, timer and ramp function.

Switching behavior

The following binary functions react to switch-on edges:

- Start, abort self-optimization
- Start, abort, start/abort timer

All remaining binary functions react to switch-on or switch-off states.

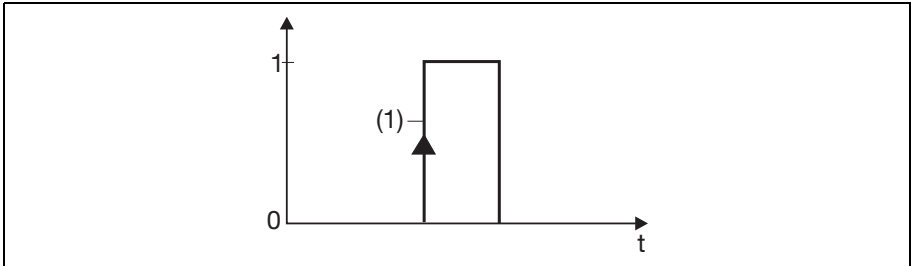

Power free contact or switching pulse

0 = Contact open

(1) = Switch-on edge

1 = Contact closed

Further functions via setup program

Several binary functions can be combined with each other in the setup program (selection under "Additional functions").

It is also possible to select "Text display" as an additional function. A maximum of 4 characters can be entered as text ("Text display" button) and displayed with a 7-segment display. The text appears in the lower display when the binary function is active.

7 Configuration level

CONF -> binf ->

Parameters	Value/ Selection	Description
Binary inputs bin1 bin2 1	0	no function
	1	Start self-optimization
	2	Abort self-optimization
	3	Change to manual mode
	4	Controller off (controller outputs are switched off)
Limit comparators LC1 LC2	5	Switch on controller
	6	Inhibit manual mode
	7	Stop ramp
	8	Abort ramp
	9	Restart ramp
Timer signal TF1	10	Set point value toggling: 0/Contact open=Set point value 1 active, 1/Contact closed= Set point value 2 active)
Ramp end signal rEnd	11	(reserved)
	12	(reserved)
	13	(reserved)
Tolerance band signal, ramp tol5	14	(reserved)
	15	(reserved)
	16	Key inhibit
	17	Level inhibit: The parameter and the configuration level are inhibited. Start of self-optimization is inhibited
	18	Display off with key inhibit
	19	(reserved)
	20	Timer acknowledgement
	21	Starting the timer
	22	Timer abort
	23	Timer stop
	24	Timer start/abort

¹ For activation of binary input 2 the setup program is required (Hardware assistant).

7 Configuration level

7.8 Display/Operation/Service counter



Both displays can be adapted to the respective requirements by the configuration of the displayed value, the decimal place and the automatic change (timer).

The time-out of the operation, the function key assignment and the level inhibit can also be configured.

CONF -> d, SP ->

Parameters	Value/ Selection	Description
Upper display d, SU	(analog selector) Process value	Display value for the upper display ⇒ Analog selector, page 34
Lower display d, SL	(analog selector) Current set point value	Display value for the lower display ⇒ Analog selector, page 34
Display change to timer value d, St		Time appears in the lower display (only effective after the timer is started) 0 no function 1 Display of residual timer time 2 Display of timer run time
Time-out tout	0... 180 ... 255	Time period in seconds, after which the device automatically returns to normal display if no key is pressed.
Restart time tRES (Power ON delay)	0...9999	Start delay time in seconds after Power ON All functions of the device are only active after this time has elapsed.



7 Configuration level

Parameters	Value/ Selection	Description
Decimal place <i>dECP</i>	0 1 2	no digit after the decimal point one digit after the decimal point two digits after the decimal point If the value to be displayed cannot be shown including the programmed decimal point, the number of digits after the decimal point are automatically reduced. If subsequently the measured value contains less digits, the reading appears with the decimal point as programmed.
Function key short  <i>tAS</i> (Push time < 2 seconds)	0 no function 1 2 3 4 5	Function if the key is briefly pressed in the normal display (max. two seconds) Starting the timer Timer abort Stop timer/continue timer run Timer start/abort Display timer value (manual)
Function key long  <i>tASL</i> (Push time >2seconds)	0 Change to manual mode 1 2 3 4 5	Function if the key is pressed for more than two seconds in the normal display Starting the timer Timer abort Stop timer/continue timer run Timer start/abort Display timer value (manual)

7 Configuration level

Parameters	Value/ Selection	Description
Level inhibit (Setup)	None	<p>Access to the individual levels can be inhibited.</p> <p>Setting in the setup program (-> Display/Operation/Service counter -> Operation):</p> <ul style="list-style-type: none">-None-Configuration level-Parameter and configuration level-Operator, parameter and configuration level <p>The setting is independent of binary function „Level inhibit“.</p> <p>When inhibiting the parameter level, the self-optimization start is simultaneously inhibited.</p>

7 Configuration level

Parameters	Value/ Selection	Description
<p>Service interval (Setup)</p> <p>□ [AL]</p>	<p>Number: 0... 9999000</p> <p>Time (h): 0...999</p> <p>Time (d): 0...999</p>	<p>Limit value for service counter (when select. „Number“ in increm. of 1000) 0 = Service counter switched off</p> <p>The service counter can be used to monitor a binary signal in respect to number (switch-on edge) or time (ON state).</p> <p>The service counter is started when entering a value > 0. When the limit value is exceeded, a signal is generated which can be put out to a binary output.</p> <p>The signal can only be acknowledged by resetting the limit value to zero (service counter switched off).</p> <p>The counter value is saved every hour in the EEPROM; the counter value saved last is used to continue counting after a power failure.</p> <p>Special features on the device when selecting "Number" (operation and display on in the user level):</p> <ul style="list-style-type: none"> - Value range: 0...9999 (1 corresponds to 1000) - Counter reading is displayed in Thousand (1 corresponds to 1000); when the counter value is below 1000, the display shows 0. - Simultaneously press the  +  keys: The complete counter value is displayed on both displays for approx. 3s. Example: Counter value 1234567; upper display = 1234, lower display = 567 <p>Setting in the setup program (-> Display/Operation/Service counter -> Service counter)</p>
<p>Service type (Setup)</p>	<p>Monitoring number</p>	<p>Selection of the interval type</p> <p>Setting in the setup program (-> Display/Operation/Service counter -> Service counter):</p> <ul style="list-style-type: none"> - Monitoring number (quantity) - Monitoring time (h) - Monitoring time (d)

7 Configuration level

Parameters	Value/ Selection	Description
Signal to be monitored (Setup)	Controller output 1	Selection of the binary signal to be monitored Setting in the setup program (-> Display/Operation/Service counter -> Service counter): - deactivated - Controller output 1 - Controller output 2 - Binary input 1 - Binary input 2 - Limit comparator 1 - Limit comparator 2 - Timer signal - Timer runs - Timer completed - Timer waiting - Tolerance band signal - Ramp end - Service alarm - Key actuation - Manual mode
User level (Setup)		A maximum of eight parameters from the various levels can be defined to be available in the user level of the device. The parameter name (max. 4 characters which can be displayed with 7-segment display) can be user-defined. Without a user-default entry, the name programmed in the device will appear. Setting in the setup program (-> Display/Operation/Service counter -> User level)

7 Configuration level

7.9 Interface

The device can be integrated into a data network (Modbus) via an optional RS485 interface.

CONF -> INTF ->

Parameters	Value/ Selection	Description
Baud rate <i>bdr</i>	0 9600 bps 1 19200 bps 2 38400 bps	
Data format <i>dft</i>	0 8 data bits, 1 stop bit, no parity 1 8 data bits, 1 stop bit, odd parity 2 8 data bits, 1 stop bit, even parity 3 8 data bits, 2 stop bits, no parity	
Device address <i>Rdr</i>	0...1... 255	Address in data network
Min. response time (Setup)	0... 500ms	Time period in milli-seconds that elapses between the request of a device in the data network and the response of the controller. Setting in the setup program (-> Interface)



TIP!

When the communication takes place via the setup interface, the RS485 interface is inactive.



TIP!

For further information a separate interface description Modbus (B70.2070.2.0) is available as a PDF file (on the mini-CD or via internet).

8.1 Technical Data

Thermocouple input

Designation	EN	Measuring range ¹	Measuring accuracy ²	Ambient temperature coefficient
Fe-CuNi „L“		-200... +900 °C	≤ 0.25%	100 ppm/K
Fe-CuNi „J“	60584	-200...+1200 °C	≤ 0.25%	100 ppm/K
Cu-CuNi „U“		-200... +600 °C	≤ 0.25%	100 ppm/K
Cu-CuNi „T“	60584	-200... +400 °C	≤ 0.25%	100 ppm/K
NiCr-Ni „K“	60584	-200...+1372 °C	≤ 0.25%	100 ppm/K
NiCr-CuNi „E“	60584	-200... +900 °C	≤ 0.25%	100 ppm/K
NiCrSi-NiSi „N“	60584	-100...+1300 °C	≤ 0.25%	100 ppm/K
Pt10Rh-Pt „S“	60584	0... +1768 °C	≤ 0.25%	100 ppm/K
Pt13Rh-Pt „R“	60584	0... +1768 °C	≤ 0.25%	100 ppm/K
Pt30Rh-Pt6Rh „B“	60584	0... +1820 °C	≤ 0.25% ³	100 ppm/K
W5Re-W26Re „C“		0... +2320 °C	≤ 0.25%	100 ppm/K
W3Re-W25Re „D“		0... +2495 °C	≤ 0.25%	100 ppm/K
W3Re-W26Re		0... +2400 °C	≤ 0.25%	100 ppm/K
Cold junction: Pt100 internal				

¹ The specifications refer to an ambient temperature of 20 °C.

² Incl. measuring accuracy at the cold junction. The accuracy values refer to the maximum measuring range. Small measuring ranges lead to reduced linearisation accuracy.

³ In the range of 300... 1820 °C

RTD temperature probe input

Designation, Connection type	Measuring range	Measuring accuracy ¹	Ambient temperature coefficient
Pt100 EN 60751 2 wire connection 3 wire connection	-200...+850 °C	≤ 0.4% ≤ 0.1%	50 ppm/K

8 Supplement

Designation, Connection type	Measuring range	Measuring accuracy ¹	Ambient temperature coefficient
Pt1000 EN 60751 2 wire connection 3 wire connection	-200...+850°C	≤ 0.2% ≤ 0.1%	50ppm/K
KTY11-6 2 wire connection	-50...+150°C	≤ 2.0%	50ppm/K
Sensor lead resistance: max. 30Ω per lead with three wire circuit			
Measuring current: approx. 250μA			
Lead compensation: Not required for three wire circuit. For a 2-wire circuit, the lead resistance can be compensated by correcting the actual value.			

¹ The accuracy values refer to the maximum measuring range. Small measuring ranges lead to reduced linearisation accuracy.

Standard signals input

Measuring range	Measuring accuracy ¹	Ambient temperature coefficient
Voltage 0(2)–10V Input resistance $R_E > 100k\Omega$	≤ 0.1%	100ppm/K
Current 0(4)–20mA Voltage drop ≤ 2.2V	≤ 0.1%	100ppm/K

¹ The accuracy values refer to the maximum measuring range. Small measuring ranges lead to reduced linearisation accuracy.

Binary inputs

Potential-free contact	open = inactive; closed = active
------------------------	-------------------------------------

Measuring circuit monitoring

In the event of a fault, the outputs change to defined statuses (configurable).

Sensor	Ovrange/ underrange	Probe/ lead short- circuit	Probe/ lead break
Thermocouple	•	-	•
RTD temperature probe	•	•	•
Voltage 2–10V 0–10V	• (•)	• -	• -
Current 4–20mA 0–20mA	• (•)	• -	• -

• = detected - = not detected
(•) = only overranges are detected

Outputs

Relay (N/O) Contact rating Contact life	max. 3A at 230V AC resistive load 150,000 operations at rated load 350,000 operations at 1A 310,000 operations at 1A and $\cos\varphi > 0.7$
Logic output	0/14V / 20mA max.
Voltage (option) Output signals Load resistance Accuracy	0–10V / 2–10V $R_{Load} \geq 500\Omega$ $\leq 0.5\%$
Current (option) Output signals Load resistance Accuracy	0–20mA / 4–20mA $R_{Load} \leq 500\Omega$ $\leq 0.5\%$

8 Supplement

Controller

Controller type	2-state, 3-state, modulating controller, continuous controller
Controller structures	P/PI/PD/PID
A/D converter	16 bit resolution
Sampling cycle time	250ms

Timer

Accuracy	$\pm 0.8\% \pm 25\text{ppm/K}$
----------	--------------------------------

Electrical data

Supply voltage (switch mode PSU)	AC 110–240V -15/+10%, 48–63Hz AC/DC 20–30V, 48–63Hz		
Electrical safety	acc. to EN 61010, part 1 Overvoltage category III, pollution degree 2		
Amperage	max. 13VA		
Data backup	EEPROM		
Electrical connection	at the back via screw terminals, Conductor cross section up to max. 2.5mm ² (for type 702071 up to max. 1.3mm ²)		
	Installation information on conductor cross sections		
		Type 702071	Type 702072 Type 702074
	1 wire	$\leq 1.3\text{mm}^2$	$\leq 2.5\text{mm}^2$
	fine-strand, with core-end ferrule	$\leq 1.0\text{mm}^2$	$\leq 1.5\text{mm}^2$
Electromagnetic compatibility	EN 61326-1		
Interference emission	Class A		
Interference immunity	Industrial requirements		

Case

Case type	Plastic case for panel mounting acc. to IEC 61554
Installation depth	
Type 702071	90.5mm
Type 702072	67.0mm
Type 702074	70.0mm
Ambient/storage temperature range	-5...+55 °C / -40...+70 °C
Ambient conditions	rel. humidity < 90% annual average, no condensation
Operating position	any
Protection type	acc.to EN 60529, at the front IP 65, at the rear IP 20
Weight (fully equipped)	
Type 702071	approx. 123g
Type 702072	approx. 173g
Type 702074	approx. 252g

Interface

Interface type	RS485
Protocol	Modbus
Baud rate	9600, 19200, 38400
Device address	0—255
Max. number of stations	32

Approvals/marks of conformity

Mark of conformity	Testing laboratory	Certificates/certification numbers	Test basis	valid for
c UL us	Underwriters Laboratories	E201387-A2-UL-1	UL 61010-1, CAN/CSA C22.2 No. 61010-1	all types

8 Supplement

8.2 Alarm and fault messages

Display	Cause	Fault remedy Test/repair/replace
RLrE (factory-specific text, can be changed)	Binary function for which a text display was configured is active	Carry out the measure intended for this case
- 1999 (flashing!)	Underrange for the value being displayed.	Is the medium being measured within the range (too hot? too cold?)
9999 (flashing!)	Overrange for the value being displayed.	Check probe for break and probe short-circuit. Check the probe connection and the terminals. Check cable. Check that the connected probe complies with the configured probe type
All displays ON; lower 7-segment display flashes	Watchdog or power ON trigger initialisation (reset).	Replace controller, if initialisation takes longer than 5s.

Overrange / underrange covers the following events:

- Probe break/short-circuit
- Measured value outside the probe measuring range
- Display overflow

8.3 Self-optimization

Principle

Self-optimization (SO) is carried out according to the oscillation method and establishes the optimum controller parameters for PID or PI controllers.

Depending on the configured controller type, the following controller parameters are defined:

Proportional band (Pb), derivative time (dt), reset time (rt), cycle times (Cy), filter time constant (dF)

Depending on the range of the control deviation, the controller selects between to methods **a** or **b**:

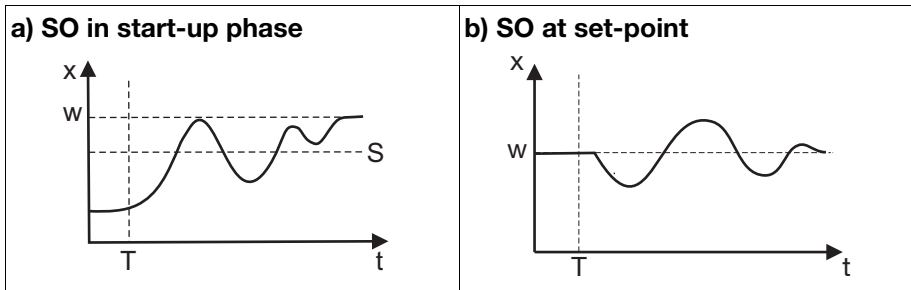



S = Switching level

T = Start of self-optimization (SO)

Prerequisites

The following prerequisites must be fulfilled to be able to start self-optimization:

- No active level inhibit via binary functions (binF)
- No active inhibit of parameter level via setup program (Display/Operation/Service counter -> Operation -> Level inhibit)
- Ensure that the the  +  keys are not pressed asynchronously. Simultaneous actuation must be synchronous.

8 Supplement

Furthermore, the following five points should be taken into consideration, checked and, if necessary, adjusted, prior to starting self-optimization:

- Is the suitable controller type configured?
- Check and/or adjust the control action of the controller
- Is it possible to sufficiently influence the process value in manual mode?
- Prior to starting optimization on PID structure, ensure that the reset time (rt) is not set to 0.
- For continuous controller only: Ensure that the function of the output (OutP -> OutA) is configured to controller output 1 and scaled to 0...100%.
This means:
Function (FnCt) = Controller output 1 (11)
Zero point (OPnt) = 0
End value (End) = 100
- For modulating controllers only: Determine the actuator time (tt) and set in the parameter level

Start of self-optimization

1. Simultaneously press the ▲ + ▼ keys (>2s)
 - ➔ In the lower display, „tUnE“ appears flashing.



Self-optimization is completed when the display automatically changes to the standard display. The duration of self-optimization depends on the process.

Canceling self-optimization

1. Cancel using ▲ + ▼ (simultaneously)



JUMO GmbH & Co. KG

Street address:

Moritz-Juchheim-Straße 1
36039 Fulda, Germany

Delivery address:

Mackenrodtstraße 14
36039 Fulda, Germany

Postal address:

36035 Fulda, Germany

Phone: +49 661 6003-0

Fax: +49 661 6003-607

E-mail: mail@jumo.net

Internet: www.jumo.net

JUMO Instrument Co. Ltd.

JUMO House

Temple Bank, Riverway
Harlow, Essex CM20 2DY, UK

Phone: +44 1279 635533

Fax: +44 1279 635262

E-mail: sales@jumo.co.uk

Internet: www.jumo.co.uk

JUMO Process Control, Inc.

8 Technology Boulevard
Canastota, NY 13032, USA

Phone: 315-697-JUMO
1-800-554-JUMO

Telefax: 315-697-5867

E-mail: info@jumo.us

Internet: www.jumo.us