

# Series 9000 H

## Heated Hydrocarbon Analyzer



## Analyzer

The Baseline® Series 9000 H is a high-temperature member of the extraordinary Series 9000 family of gas analyzers. The Series 9000 is the candidate of choice whenever accurate, reliable hydrocarbon analysis is required.

The Series 9000 H has a dynamic range from 0.1 ppm to 10% (Propane) or 0.3 ppm to 50% (Methane). The analyzer has a generous complement of analog, digital and logic output capabilities. These features place the instrument well ahead of the competition in performance, automation, and configurability.

The analyzer is based on a flame ionization detector (FID) with FlowGuard electronic control that delivers a small portion of the sample gas to the detector flame. During the combustion process, organic or hydrocarbon-based gases in the sample are ionized then they can be detected by the instrument and reported as a concentration.

The Series 9000 H is configured for single point analysis of samples heated up to 376 °F (191°C). The automatic calibration feature enhances the long-term analytical stability of the instrument.

## Applications

The Series 9000 H is designed to continuously monitor the total hydrocarbon content of gases and maintain the temperature of heated sample above their dew point. This extremely versatile instrument can be configured to support a variety of applications, such as:

- Compliance monitoring for EPA Methods 25A & 503
- Continuous Emission Monitoring (CEM) of source hydrocarbons
- Scrubber & oxidizer efficiency
- Carbon bed breakthrough detection
- LEL monitoring
- Vehicle emissions
- Chemical process blending

## Features

- Flame ionization detector.
- 3U case, 19" (48.3cm) rack mountable.
- Hydrocarbon detection from sub-ppm to 50% levels (Methane).
- Automatic calibration at user-defined intervals.
- Internal, multipoint sampling option.
- **FlowGuard** electronic control of fuel, air and sample.
- Electronic back-pressure regulator with sample bypass system ensures fast response.
- Discrete, multilevel concentration & fault alarms.
- Programmable relays for concentration alarms, events and diagnostics.
- Automatic FID ignition, with automatic shut-off of sample, fuel and combustion air.
- Remote operation via RS-232 and Ethernet.
- Graphical display and easy to use menu system.
- Optional 9000 Keeper software to monitor and control the instrument remotely.

# Series 9000 H

## Heated Hydrocarbon Analyzer

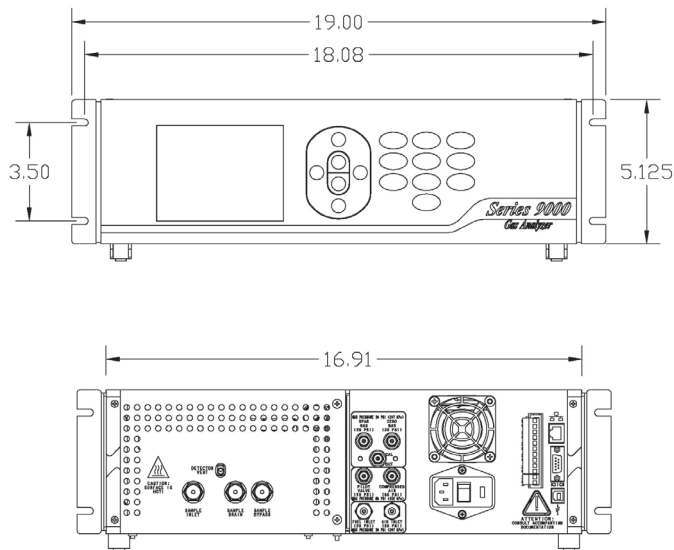

### Analytical

**Detector:** Flame ionization detector (FID).

**Sample Temperature:** Up to 376 °F (191 °C).

#### Ranges:

MDQ 0.3ppm, Full-scale 1 to 2,000ppm (Methane)

MDQ 0.6ppm, Full-scale 1 – 20,000ppm (Methane)

MDQ 0.003%, Full-scale 0.01 – 50% (Methane)

**Repeatability:** +/- 1% Full-scale response.

**Drift:** +/- 1% of Full-Scale over 24 hours.

**Response Time:** T90 < 5 sec.

**Alarms:** Multilevel concentration and fault alarms that result in audible and visual alarms. Alarms may also be mapped to relays to control external equipment.

**Sampling:** Internal single or multipoint modules for pre-filtered (<0.1 microns), non-condensing samples, with or without sample pump.

**Calibration:** Programmable automatic or manual calibration.

**Support Gas:** Hydrogen 40 cc/min, Air 200 cc/min. (typical). Hydrocarbon content must be less than 1 ppm. Fuel blend options available, consult Baseline®

### Physical

**Dimensions:** 19.00" (48.3cm) W x 14.25" (36.2cm) D x 5.25" (13.3cm) H.

**Weight:** < 25 lb (11.3kg).

**Configuration:** Bench-top or rack-mount 19" (48.3cm) panel.

**Connections:** 1/4" (6.35mm) tube fitting connectors.

**Operating Temperature:** 32 - 104 °F (0 - 40 °C).

**Operating Humidity:** 0 – 95% (non-condensing).

### Electrical

**Power:** 90 – 230 VAC, 50/60Hz, 3A.

**Display:** 3.4" (8.6cm) x 4.5" (11.4cm) graphical display.

**Relay Outputs:** 5 programmable form A relays rated to 3A @ 230V AC.

**Analog Outputs:** 1 programmable 0-20mA or 4-20mA isolated output.

**Digital Outputs:** RS-232, Ethernet.

D025.2

P.O. Box 649, 19661 Highway 36 • Lyons, CO 80540

P: 1.800.321.4665 • 1.303.823.6661 F: 303.823.5151 E: Sales@BaselineIndustries.com