

Series 9000

Total Hydrocarbon Analyzer



Analyzer

The Baseline® Series 9000 is the candidate of choice whenever accurate, reliable total hydrocarbon analysis is required. The Series 9000 analyzer provides unparalleled flexibility and offers continuous, fully automated gas analysis over a broad range of concentrations.

The 9000 has a dynamic range from less than 10 ppb on the low range version and up to 100% as methane on the high range version. The analyzer has a generous complement of analog, digital and logic output capabilities.

The analyzer is based on a flame ionization detector (FID) with FlowGuard electronic control that delivers a small portion of the sample gas to the detector flame. During the combustion process, organic or hydrocarbon-based gases in the sample are ionized then they are detected by the instrument and reported as a concentration.

The Series 9000 can be configured with internal components for single or multipoint analysis of non-condensing gas samples. The automatic calibration feature enhances the long-term analytical stability of the instrument. These features place the instrument well ahead of the competition in performance, automation, and configurability.

Applications

The Series 9000 is designed to continuously monitor the total hydrocarbon content of non-condensing gases in a variety of applications, such as:

- Beverage grade CO₂ analysis
- Scrubber & oxidizer efficiency
- Carbon bed breakthrough detection
- Contaminant analysis in pure/ultrapure inert gases
- Well logging
- Industrial hygiene & safety monitoring
- Fenceline (perimeter) monitoring around industrial sites
- LEL monitoring

Features

- Flame ionization detector.
- 3U case, 19" (48.3cm) rack mountable.
- Automatic calibration at user-defined intervals.
- Internal, multipoint sampling option.
- **FlowGuard** electronic control of fuel, air and sample.
- Electronic back-pressure regulator with sample bypass system ensures fast response.
- Discrete, multilevel concentration & fault alarms.
- Analog output ranges programmable from 1 ppm – 100% full scale.
- Programmable relays for concentration alarms, events and diagnostics.
- Automatic FID ignition, with automatic shut-off of sample, fuel and combustion air.
- Remote operation via RS-232 and Ethernet.
- Graphical display and easy to use menu system.
- Optional 9000 Keeper software to monitor and control the instrument remotely.



CERTIFIED ISO 9001:2000

Series 9000

Total Hydrocarbon Analyzer

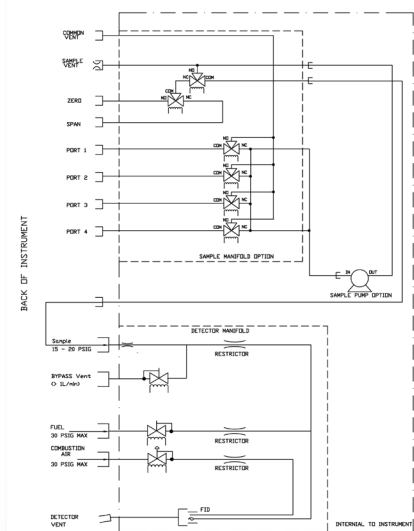
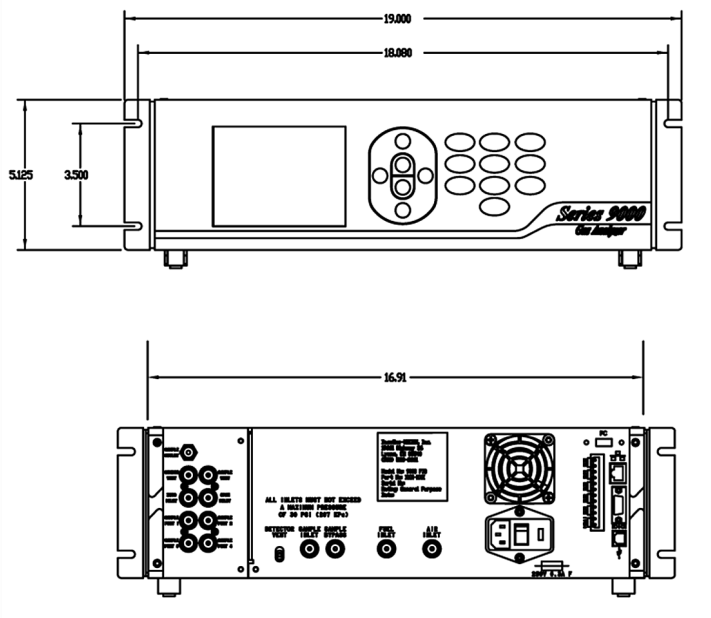

Analytical

Detector: Flame ionization detector (FID).

Ranges:

- MDQ 0.01ppm, Full-scale 1 - 200ppm (Methane)
- MDQ 0.1ppm, Full-scale 1 - 2,000ppm (Methane)
- MDQ 0.3ppm, Full-scale 1 - 20,000ppm (Methane)
- MDQ 0.003%, Full-scale 0.01 - 100% (Methane)

Repeatability: +/- 1% Full-scale response.

Drift: +/- 1% of full-scale over 24 hours.

Response Time: < 5 seconds to 90% of final reading.

Alarms: Multilevel concentration and fault alarms that result in audible and visual alarms. Alarms may also be mapped to relays to control external equipment.

Sampling: Internal single or multipoint modules, for pre-filtered (<0.1 microns) non-condensing samples, with or without sample pump.

Calibration: Programmable automatic or manual calibration.

Support Gas: Hydrogen 35 cc/min, Air 175 cc/min (typical). Hydrocarbon content must be less than 1 ppm. Fuel blend options available, consult Baseline®.

Physical

Dimensions: 19.00" (48.3cm) W x 14.25" (36.2cm) D x 5.25" (13.3cm) H.

Weight: < 20 lb (9.07kg).

Configuration: Bench-top or rack-mount 19" (48.3cm) panel.

Connections: 1/4" (6.35mm) tube fitting connectors.

Operating Temperature: 32 - 104 °F (0 - 40 °C).

Operating Humidity: 0 - 95% (non-condensing).

Electrical

Power: 90 - 230 VAC, 50/60Hz, 3A.

Display: 3.4" (8.6cm) x 4.5" (11.4cm) graphical display.

Relay Outputs: 5 programmable form A relays rated to 3A @ 230V AC (optional additional 9 relay output board).

Analog Outputs: 1 programmable 0-20mA or 4-20mA isolated output (optional additional 3 analog output board).

Digital Outputs: RS-232, Ethernet.

D011.3

P.O. Box 649, 19661 Highway 36 • Lyons, CO 80540

P: 1.800.321.4665 • 1.303.823.6661 F: 303.823.5151 E: Sales@BaselineIndustries.com