

GMD/W20 Series Carbon Dioxide Transmitters for Demand Controlled Ventilation Applications



The GMD/W20 series transmitters are designed for use in ventilation-related applications.

Features/Benefits

- Versatile transmitters
- Duct and wall mount models
- Incorporates Vaisala CARBOCAP® Sensor - the silicon-based NDIR sensor
- Excellent long-term stability
- Negligible temperature dependence
- Ease of installation

The duct mounted Vaisala CARBOCAP® Carbon Dioxide Transmitter Series GMD20 and wall mounted GMW20 are specially designed for Demand Controlled Ventilation (DCV). They are easy to install and require no maintenance. The recommended calibration interval is five years.

Vaisala CARBOCAP® technology

The GMD/W20 Series Transmitters use the silicon-based Vaisala CARBOCAP® Sensor. The simple structure and reference measurement capabilities make this Single-Beam, Dual-Wavelength NDIR sensor extremely stable and reliable.

The temperature and flow dependences of the sensor are negligible. In addition, the measurement accuracy is not affected by dust, water vapor and most chemicals.

Versatile transmitters

The GMD/W20 series transmitters can be used independently, or incorporated into building energy management systems. The series consists of duct mount units GMD20/D and wall mount units GMW21/D and GMW22/D. Version D has a display. The two sizes in the wall-mount series make them easy to install for most standard junction boxes.

The duct units' compact sensor head design requires only a small hole in a ventilation duct, thereby minimizing the risk of leaking gaskets and measurement errors.

In addition to the standard 0 ... 20 mA, 4 ... 20 mA and 0 ... 10 V outputs, there are three other options: two LonWorks® interfaces and a relay output. The relay output is standard with the display units.

Improve indoor air at minimal energy costs

The use of the GMD/W20 series transmitters ensures the best possible control of air quality and results in considerable savings in energy consumption, maintenance and recalibration costs.

Temperature option

The GMA20T temperature module, an option with the GMW21 wall mount unit, combines both CO₂ and temperature measurement into one transmitter. The GMA20T has an output of 0 ... 10 V corresponding to a temperature range of 0 ... +50 °C (+32 ... +122 °F).

Technical Data

Performance

Carbon dioxide measurement

Measurement range	0 ... 2000 ppm (nominal; can be calibrated for other ranges: 0 ... 5000 ppm, 0 ... 10,000 ppm, 0 ... 20,000 ppm)
Accuracy (including repeatability, non-linearity and calibration uncertainty)	± (2 % of range + 2% of reading)
Long-term stability	<±5 % of range / 5 years
Response time (63%)	1 minute
Warm-up time	1 minute, 15 minutes full specifications
Temperature measurement (optional with GMW21)	
Output signal	0 ... 10V
Corresponding measurement range	0 ... +50 °C (+32 ... +122 °F)
Accuracy at +25 °C	±0.5 °C (0.9 °F)
Warm up time	30 min
Temperature sensor	Semiconductor IC

Inputs and outputs

Outputs	0 ... 20 or 4 ... 20 mA and 0 ... 10 V
Optional outputs	relay LonWorks® interface
Resolution of analog outputs	8 bits
Recommended external load:	
current output	max. 500 ohm
voltage output	min. 1 kohm
Operating voltage	nominal 24 VAC/DC (18 ... 30 VDC)
Power consumption	<2.5 W

Operating environment

Temperature	-5 ... +45 °C (+23 ... +113 °F)
Humidity	0 ... 85 %RH, non-condensing
Flow velocity (GMD20)	0 ... 10 m/s
Electromagnetic compatibility	EN61326-1, Generic Environment

Mechanics

Housing material	ABS plastic
Housing classification (GMD20 electronics housing)	IP65
Weight:	
GMD20 (D)	140 g (170 g)
GMW21 (D)	100 g (130 g)
GMW22 (D)	90 g (120 g)

Accessories and options

Display and relay option for GMD/W21/22	GMI21
Relay output option	GMR20
LonWorks® module with CO ₂ signal (Not available when display option is added)	GML20
LonWorks® module with both CO ₂ signal and temperature signals (Not available when display option is added)	GML20T
Calibration software kit (disk and serial COM adapter)	19222GM
Analog temperature module for GMW21 (not available when display option is added)	GMA20T
Hand-held meter for field verification	GM70

Dimensions

Dimensions in mm

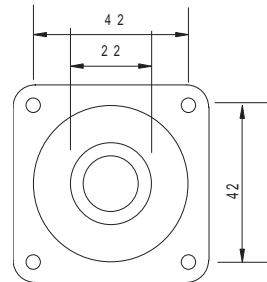
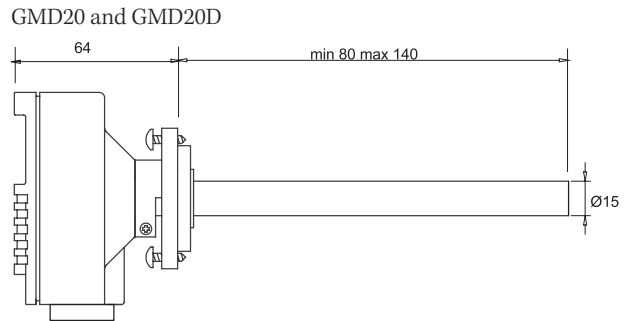

GMW21 and GMW21D

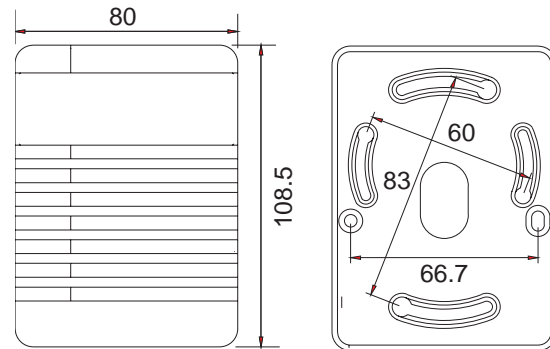

GMW22 and GMW22D

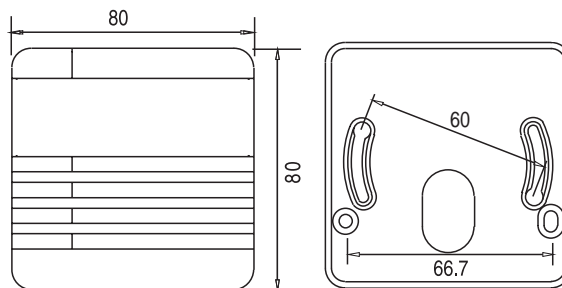

CARBOCAP® is a registered trademark of Vaisala.
Specifications subject to change without prior notice.
©Vaisala Oyj

